



DIAPHRAGM MULTI-SPRING PNEUMATIC ACTUATORS TYPE P/R

APPLICATION AREA

The multi-spring membrane pneumatic actuators of P/R type are applied for control operation of control valves and other positioning elements in industrial automatic systems.

There are three following design options of the acutator:

- direct action (air - ejects the stem) - type P,
- reverse action (air – retracts the stem) - type R,
- direct action, handwheel - type PN,
- reverse action, handwheel - type RN

FEATURES

- completely reversible action, option to change spring range w/o extra parts,
- actuator mounted on the columns,
- wide range of the available forces,
- linear relationship between rod displacement and control pressure as a result of using membranes with constant active area,
- various ranges of spring pressures due to changeability of spring number and /or dislocation of distance fencers,
- capability of the actuator o incorporate side-mounted handwheel, pneumatic or electro-pneumatic positioners, limit switches, air sets, three-way pneumatic solenoid valves, lockup valves, position transducers,
- possibility to equip with accessories allowing to decrease or increase distortion time,
- high strength of diaphragms, springs and packings,
- small size and weight



TECHNICAL PARAMETERS

input signal range:

20...100 kPa;	spring range marking:	1
40...200 kPa;		2
40...120 kPa		3
80...240 kPa;		4
60...140 kPa;		5
120...280 kPa		6
180...380 kPa		7

Number of springs:

standard version:	
range	1, 3, 5 - 3 springs
range	2, 4, 6 - 6 springs
range	7 - 12 springs
version TANDEM:	
range	1, 3, 5 - 6 springs
range	2, 4, 6 - 12 springs
range	7 - 24 springs

- working temperature:

- 40...+80°C

- relative humidity:

max. 98%

Table 1. Technical parameters.

Size	Diaphragm effective area		Stroke	Spring range marking	Max. supply pressure	
	[cm ²]				[mm]	[kPa]
250	250		20	1...6	600	
400	400					
630	630					
R-630T	2x630		20; 38	1...7	500	
1000	1000		38; 50; 63			
1500	1500		38; 50; 63; 80; 100			
1500T	2x1500		50; 63; 80; 100			

DIMENSIONS AND WEIGHT

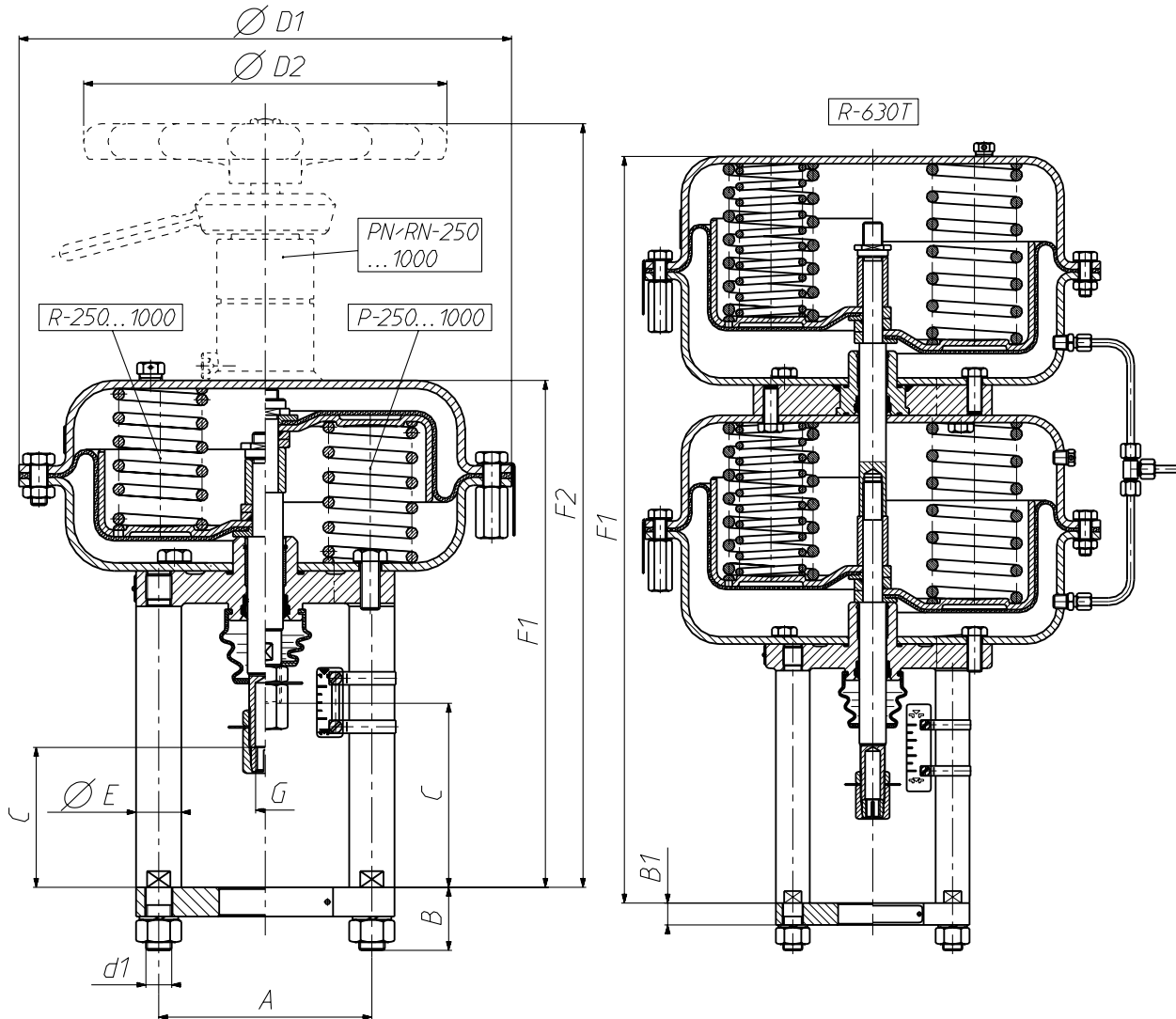

Table 2. Dimensions and weight of the actuators P/R-250...1000 .

Actuator size	A	B	B ₁	C		D ₁	D ₂	d ₁	E	F ₁	F ₂	G	Weight	
				P, PN	R, RN								P,R	PN, RN
				[mm]										
250	110	31	18	112	86	240	225	M12	22	306	468	M12x1,25	10	14,5
400	132	39		116		305				312	474		16	20,5
630				134		305	402	564	30	37				
R-630T			-	-		616	-	45	52					
1000	216	50	20	210		127	477	450	M24	42	585		825	M16x1,5

DIMENSIONS AND WEIGHT

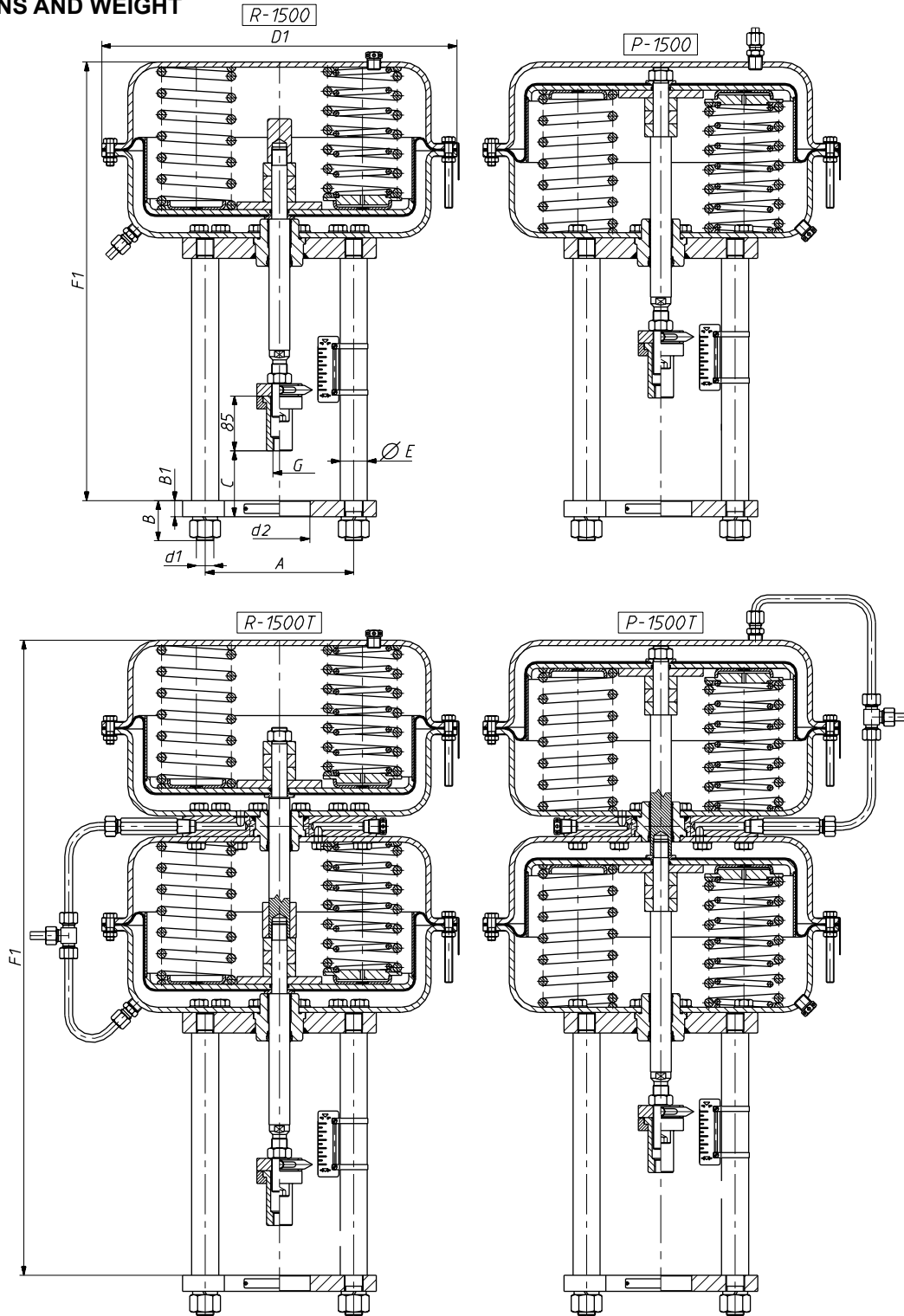

Table 3. Dimensions and weight of the actuators P/R-1500; 1500T.

Actuator size	A	B	B ₁	d ₂	D ₁	d ₁	E	F ₁	G	Weight P,R	Actuator size	Stroke	C		
	[mm]									[kg]			[mm]		P
1500	230	62	18	57,15	550	M27	42	679	M16x1,5 M20x1,5 M24x1,5	95	1500	38	142	102	
			22	84,15								50	154		
			25	70								63	167		
1500T			18	57,15						983		200	80		184
			22	84,15									100		204
			25	70									50		154
			95,25								63	167			
											80	184			
											100	204			

Disposition forces:

Disposition actuator forces F_s [kN]:

Pneumatic actuator type P:
Pneumatic actuator type R:

$$F_s = 10^{-4} \cdot A \cdot (p_z - p_2),$$

$$F_s = 10^{-4} \cdot A \cdot p_1$$

where:

- A - Diaphragm effective area [cm²] - acc. table 1,
- p_z - supply pressure [kPa] - acc. table 4
- p_1, p_2 - Opening and closing spring range [kPa] - acc. table 4.

Table 4. Disposition forces for actuators F_s [kN].

Size	Actuator P			Actuator R					
	Supply pressure			Spring range					
	[kPa]			[kPa]					
	140	250	400	20...100	40...120 40...200	60...140	80...240	120...280	180...380
250	1,0	3,8	7,5	0,5	1,0	1,5	2,0	3,0	-
400	1,6	6,0	12,0	0,8	1,6	2,4	3,2	4,8	-
630	2,5	9,5	18,9	1,3	2,5	3,8	5,0	7,6	11,3
R-630T	-	-	-	2,6	5,0	7,6	10,0	15,2	22,6
1000	4,0	15,0	30,0	2,0	4,0	6,0	8,0	12,0	18,0
1500	6,0	22,5	45,0	3,0	6,0	9,0	12,0	18,0	27,0
1500T	12,0	45,0	90,0	6,0	12,0	18,0	24,0	36,0	54,0

Note:

1. For actuators "P" assumed spring range 20...100 kPa and standard supply pressure.
2. Disposition forces calculated with the use of formulas or given in the table do not take into consideration friction or manufacture tolerances so the forces should be assumed as 15...20% lower than those values.
3. Actuator 630T occurs only in type „R”.

PRODUCT CODE

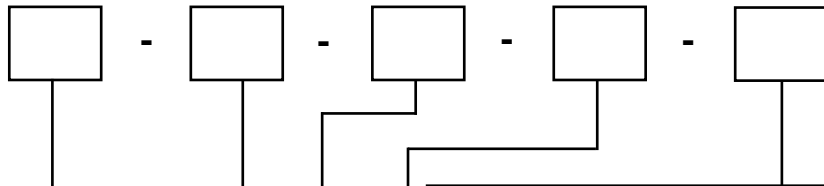

Type:

- direct action: **P**
- reverse action: **R**
- direct action, handwheel: **PN**
- reverse action, handwheel: **RN**

Size:

- 250**
- 400**
- 630**
- 630T**
- 1000**
- 1500**
- 1500T**

Threaded connection:

- M12x1,25 **12**
- M16x1,5 **16**
- M20x1,5 **20**
- M24x1,5 **24**

Spring range [kPa] / coding:

- 20...100 **1**
- 40...200 **2**
- 40...120 **3**
- 80...240 **4**
- 60...140 **5**
- 120...280 **6**
- 180...380 **7**

Stroke [mm]:

- 20**
- 38**
- 50**
- 63**
- 80**
- 100**

Example of the product code:

The pneumatic actuator of inversed action, with a handwheel, size – 400, threaded connection M12x1,25, stroke 20 mm, spring range 40...200:

RN - 400 - 20 - 2 - 12