

AX480, AX488 and AX468

Single and dual input analyzers for dissolved oxygen

More processing power
Lower energy costs



Cost effective

- select one or two dissolved oxygen inputs or combine pH/Redox (ORP) and dissolved oxygen in one analyzer

Reduced installation cost

- easy access terminations; reduced panel space

High functionality at minimum cost

- three alarms and two fully isolated current outputs
- integral Water/Chemical sensor cleaner control
- integral PID controller (AX480)

Expanded monitoring and control

- add-on option board provides up to five alarm relays and four current outputs
- service log-book providing historical data

On line assurance of reliability

- comprehensive sensor and instrument self-checking



High measurement accuracy

- salinity, temperature and atmospheric pressure compensation included

Energy saving

- high visibility backlit display with auto switch-off function

Reduced yearly maintenance costs

- 12 to 30V DC option negates the need for costly safety tests

SEITA

Servicios Especializados de Ingeniería
en Tecnología y Automatización

www.seita.com.co

Power and productivity
for a better world™



The AX400 Series

AX400 Analyzers incorporate the latest technology providing highly reliable, flexible, feature-packed devices that satisfy a diverse range of process monitoring and control applications. The complete range encompasses solutions for pH/Redox (ORP), conductivity and dissolved oxygen.

AX48x instruments enable continuous measurements of one or two dissolved oxygen points with simultaneous local display and retransmission. AX48x is used with 9408 Series immersion, submersion and self-cleaning floating-ball sensors providing measurements with exceptional accuracy and performance.

AX400 Series analyzers are available for either wall-/pipe- or panel-mounting and are rated to IP65.

High Functionality as Standard

All versions are supplied with two, fully-isolated current outputs as standard, that can be assigned to the measured parameter, sample temperature or any appropriate calculated variables.

Three programmable relay set points are available which can also be assigned as required.

Innovative features such as a power saving display and a diagnostic current output option all contribute to low cost of ownership.

Plug-and-Produce Expanded Control

An advanced function card provides an additional two current outputs and two further alarm relays that can be assigned to either measured values or sample temperature.

ABB Plug-and-Produce software automatically reconfigures the analyzer if an option board is added later. No user programming is necessary.

A real-time clock and logbook are also included making the full-facility versions extremely powerful and versatile.

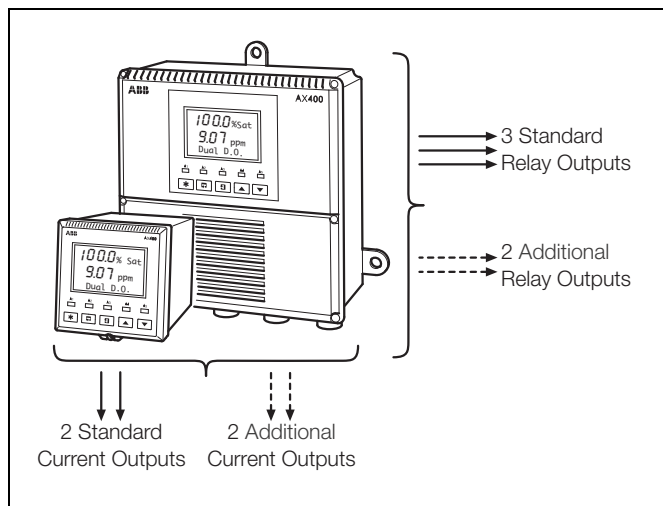

AX400 Outputs

Significantly reduced maintenance costs

The AX400 Analyzers are supplied as standard for 85 to 265V AC operation. There are no inner switches to set.

They can also be provided for 24V AC, or 12 to 30V DC, supply and recognize automatically which of the two supplies is being used. 24v DC reduces maintenance costs significantly by negating the need for costly, yearly safety tests to ensure compliance with safety procedures.

Energy Saving Display

The backlit display has been designed to operate in all types of environments and shows both the measured parameter(s) and, on a separate 16-character display line, diagnostic and computed information.

On dual-input analyzers both measured parameters are displayed simultaneously.

For conservation of energy, the backlight can be set to switch off automatically after 60s of inactivity.



Backlight can be set to switch-off when inactive

AX410, AX411, AX416, AX450 and AX455
Single and dual input analyzers for dissolved oxygen

Easy Access Installation Terminals

Easy access to the terminations ensures rapid and cost-effective installation. The wall-/pipe-mount version has been designed to ensure that cable connection is simple and convenient. Ingress protection of the electronics section is retained even when the terminal compartment cover is opened.

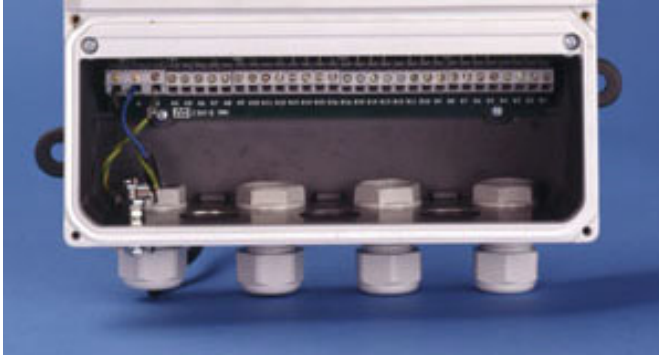

AX400 Termination Chamber Makes Access Easy

Cost Savings with Aeration Lane Zone Control

Depending on the incoming load to large aeration tanks, the profile of horizontal oxygen can change considerably. Controlling the entire tank based solely on a final measurement can be extremely inefficient.

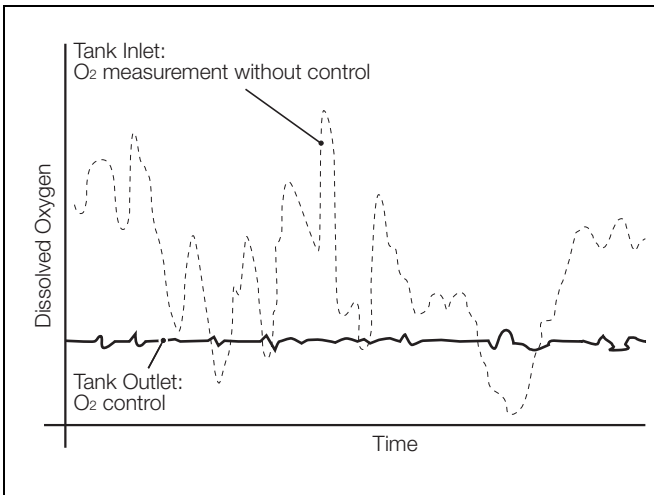

Control in Several Zones Saves Costs

Controlling several sections individually can considerably increase the tank capacity and bring additional savings in energy. The AX488 enables two continuous measurements from a single analyzer with simultaneous local display and retransmission.

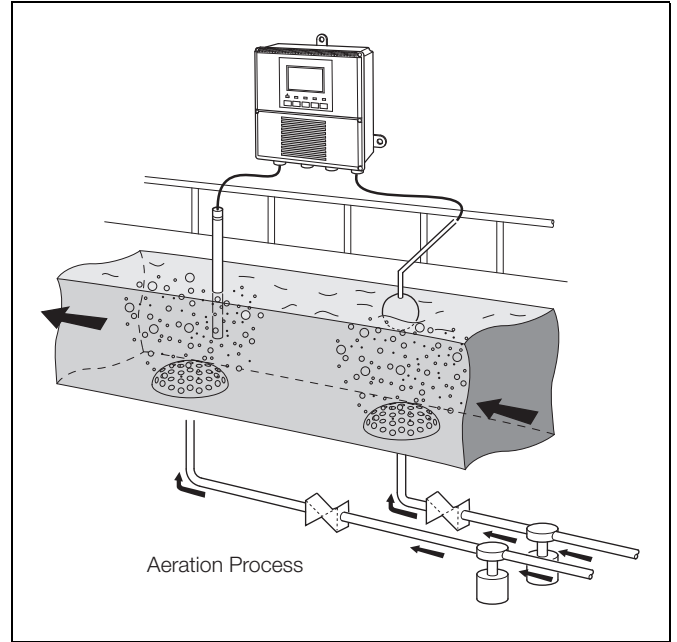

Dual-input Enables Zone Control for Optimum Tank Capacity and Reduced Energy Costs

The AX488 operates as two separate analyzers, thus reducing initial expenditure, saving space and minimizing installation costs when compared to using two individual analyzers. This capability provides on-line validation of the process measurement.

Making two simultaneous measurements and configuring one of the set points as a difference alarm provides continuous on-line checking and early warning of malfunction of the measurement.

Alternatively, both measurements can be compared and an average value calculated and transmitted via the analog output.

In aeration lanes where four individual measurements are made, two AX488s can considerably reduce capital expenditure.

AX410, AX411, AX416, AX450 and AX455
 Single and dual input analyzers for dissolved oxygen

On-line Assurance of Reliability

The AX48x displays a bar-graph of the sensor's output after calibration. This unique feature provides information on the sensor condition and enables maximum use of the sensor before replacement.

Sensor capsule replacement is a simple operation that can be carried out in a few minutes.

Bars	Sensor Output Efficiency
	> 85%
	> 60%
	> 50%
	< 50% Low Sensor Efficiency

Bargraph Sensor Life Indicator

Reduced Maintenance Through In-line Cleaning

Many installed sensors benefit from regular cleaning. When carried out manually, this can be laborious and costly – so is often ignored. Advanced AX48x analyzers make it possible to automate sensor cleaning of floating ball, immersion or submersible systems by using a programmable wash-timer contact to activate a cleaning agent valve or pump.



Efficient Jet-spray Cleaning Control

Pulsed water-wash and jet-wash chemical clean actions are standard, user-selectable functions. The frequency and duration of the wash can be tuned to meet the needs of the application.

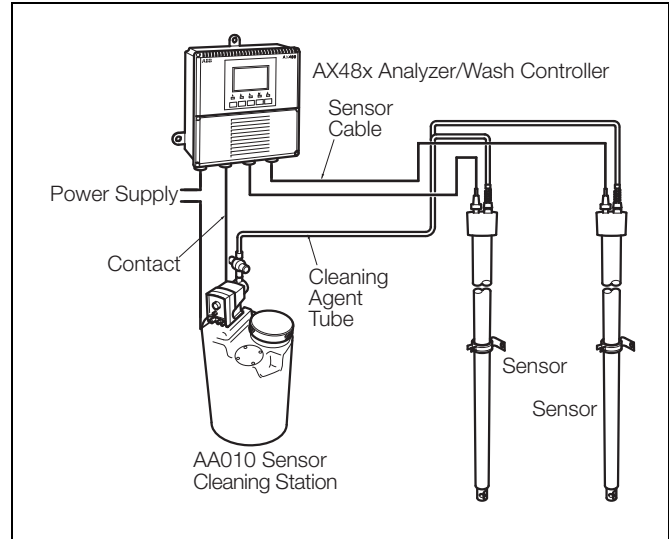

Efficient Auto-cleaning Control for One or Two Sensor Systems

For chemical cleaning a 60 liter (13 gallon) sensor cleaning station can be supplied (model no. AA0010), complete with delivery pump and low level alarm. Chemical cleaning has proved particularly successful on potable drinking water plants where manganese and iron in the sample can create unacceptably high levels of maintenance. Effective cleaning reduces cost of ownership.

AX410, AX411, AX416, AX450 and AX455
Single and dual input analyzers for dissolved oxygen

Combined Dissolved Oxygen and pH or Redox (ORP)

The AX468 version measures pH or Redox (ORP) and dissolved oxygen with the same analyzer. The option board provides the capability to retransmit pH, dissolved oxygen and both sample temperatures. Five programmable alarms can be assigned to suit the needs of the application, enabling even the most demanding requirements to be met.



Simultaneous pH and Dissolved Oxygen Measurement

Confidence in Service

To complement the well-proven design, unrivalled accuracy and reliability in service of the dissolved oxygen sensor, the entire sensing loop is regularly self-monitored for short circuits and temperature element faults. The instrument incorporates a nonvolatile memory, eliminating the need for battery back-up, and line-voltage supply filtering to minimize the effects of mains borne interference.

Temperature Compensation, Salinity and Pressure Correction Factor

The solubility of oxygen in water is affected by:

1. sample temperature
2. solution salinity
3. atmospheric pressure

The AX48x analyzer uses a Pt100 temperature sensor to apply automatic compensation for the effects of temperature on the oxygen permeability of the sensor membrane. Parameters such as salinity in ppm and barometric pressure, or height above sea level, can also be entered during calibration to compensate for these effects.

AX480 Integral P, PI and PID Control

The single input AX480 analyzers incorporate three-term PID Control, offering three modes of sophisticated control: analog, pulse length (time proportional) and pulse frequency. These are supplied as standard and can be operated in direct- or reverse-acting mode, depending upon the application.

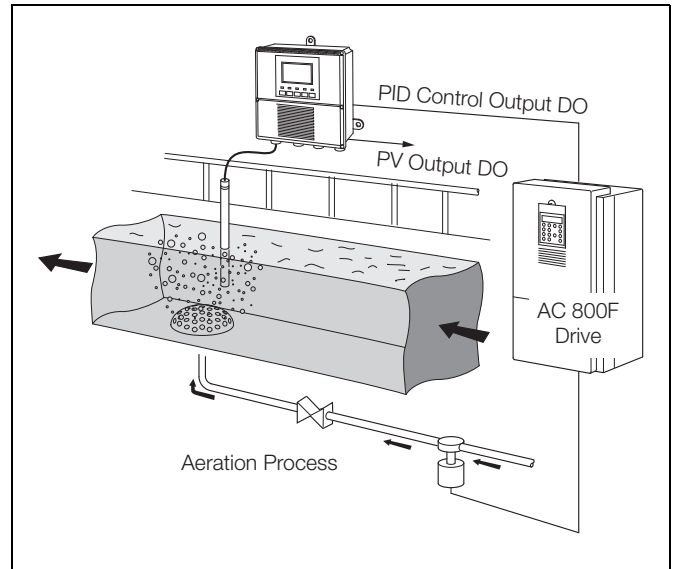

AX480 with Integral PID Controller

Auto/Manual and Bumpless Transfer

An auto/manual feature is incorporated for rapid manual access to the control functions. The controller facilitates bumpless transfer between manual and auto modes, providing the measured variable is within the proportional band and some integral action time has been programmed.

Current Output Proportional Control

In this case, the control signal is provided by the 4 to 20mA output of the AX480 analyzers rather than using the alarm/control contacts. The magnitude of the current output changes in proportion to the deviation from set point. This method is used generally with motorized valves or when controlling the speed of dosing pumps with a 4 to 20mA proportional input.

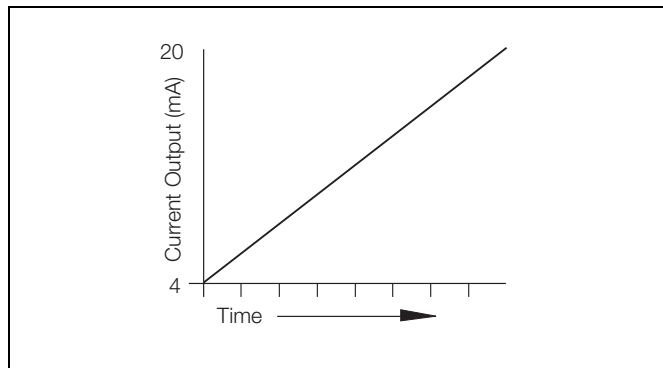

Current Acting Control

Time Proportioning Control (Pulse Length)

With time proportioning control, the AX480 analyzer's control signal output is in pulses, the duration of which changes in proportion to the system error. The pulses are delivered by varying the length of time that the alarm/control contact is activated.

Time Proportioning Control is used generally to control dosing by low-cost solenoid valves or metering pumps and is also known as pulse-length proportional or Mark Space control.

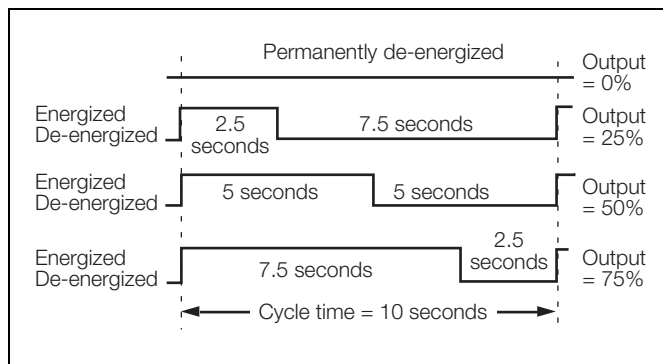

Time Proportioning Control

Pulse-frequency Proportional Control

Impulse pumps dosing chemical reagents are controlled easily by the AX480's pulse-frequency proportional control output. In this case, the pulse length of the alarm/control contact is fixed and the frequency of the delivered pulses increases in proportion to the system error, as set by the proportional band. Diaphragm metering pumps must have a remote pulse input capability in order to utilize this function.

Pulse frequency control in the AX480 operates by pulsing a relay on for 300ms and off for a period of time determined by the pulse frequency. The pulse frequency (PFR) is adjustable between 1 and 120 pulses per minute. The greater the difference between the measured variable and the set point, the greater the pulse frequency.

Example

If the pulse frequency is set at 120 pulses per minute and the percentage output is 100% then the pulse rate is 2 pulses per second. If the percentage output is reduced to 50%, the pulse rate falls to one pulse per second.

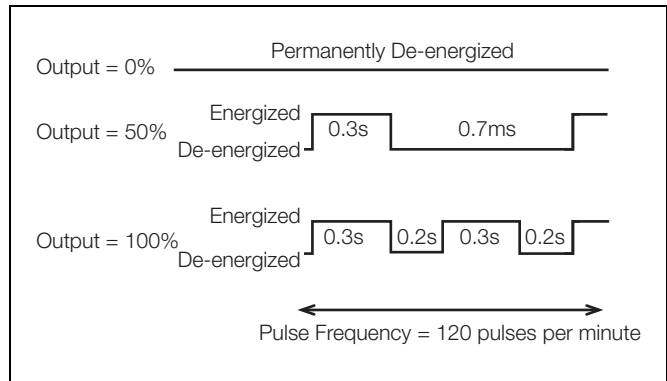

Pulse-frequency Proportional Control

Power Failure Recovery

In the event of a power failure the user can configure the control mode to be Auto, Manual or Last. This optimizes control conditions on power-up to ensure rapid recovery of process control.

AX410, AX411, AX416, AX450 and AX455
Single and dual input analyzers for dissolved oxygen

9408 Dissolved Oxygen Sensor Systems

AX480, AX488 and AX468 dissolved oxygen analyzers are designed specifically to operate with the industry-proven, anti-fouling 9408 Series sensors.

Reliable monitoring of dissolved oxygen levels in waste treatment tanks can be hampered by sensor fouling with rags or other large solids. 9408 sensors can be supplied with anti-fouling, floating ball systems making rags and solids difficult to lodge. In addition, all 9408 systems can be equipped with a powerful jet-wash facility for removal of tough deposits.

Each sensor system includes an 8012-170 sensor capsule. This is mounted in a support tube with an integral temperature sensor for automatic temperature compensation and measurement. Maintenance simply involves a quick plug-in of a replacement capsule. Lifetime is typically 9 to 12 months and in many cases longer.

- Reduced sensor fouling
 - Large diameter, floating ball repels rags and coating
 - Optional jet-wash system for stubborn deposits
- Low maintenance, long-life sensor
 - No changing of electrolyte or membrane
 - Simple replacement, plug-in cartridge
- Simple calibration
 - Zero calibration is not essential
 - Simple, single-point air calibration
- Comprehensive mounting methods
 - Floating ball, immersion, submersion and flow-through systems available

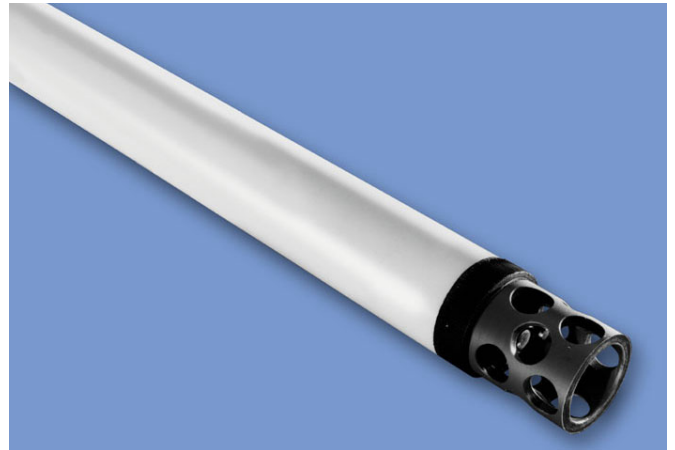

9408 Immersion System



9408 Submersible System

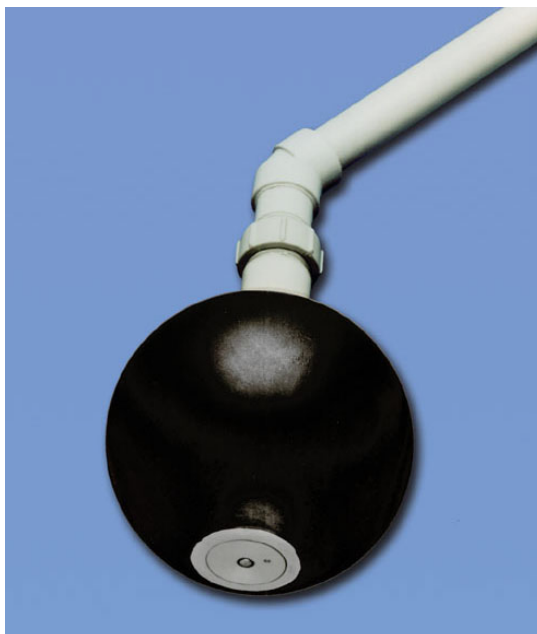

9408 Floating Ball System



9408 Flow-through Cartridge System

AX410, AX411, AX416, AX450 and AX455

Single and dual input analyzers for dissolved oxygen

Specification – Sensor Systems

General

Sensor

8012-170 sensor capsule

Response

Typically 20s for 90% of a step-change of oxygen concentration at 20 °C (68 °F)

Temperature compensation

Automatic correction with integral Pt100 temperature sensor

Operating temperature

0 ... 40 °C (32 ... 104 °F)

Operating pressure

Atmospheric

Minimum liquid velocity

30 cm/s

Accuracy

±0.2 mg/l or ±2% saturation within ±10 °C (±50 °F) of the calibration temperature in the range 0 ... 35 °C (32 ... 95 °F)

Connection cable

Part no. 0233-828

Maximum length

100 m (32.5 ft)

Floating Ball Systems

Materials of construction

- Support arm – ABS plastic
- Flotation collar – Polypropylene
- Mounting bracket – Stainless steel

Mounting

Pipe mounting – 50 mm (2 in) OD

Support arm length (9408-70x only)

3 m (10 ft)

Immersion Systems

Materials of construction

Polypropylene

Mounting

Wall-mounting bracket

Immersion lengths

1, 2, 3 m (3.3, 6.6, 10 ft)

Submersible Systems

Materials of construction

Polypropylene

Mounting

Support chain (user supplied)

Cable length

8 m (26 ft)

Flow-through Cartridge Systems

Operating pressure

2 bar (30 psi)

Minimum flow rate

2 l/min

Materials of construction

Polypropylene

Mounting

Support chain (user supplied)

Process connections

- 1/2 in or 1 in BSP inlet and outlet
- 1/2 in or 1 in NPT inlet and outlet

Cable lengths

1, 3, 5, 10 and 20 m (3, 9, 15, 30 and 60 ft approx.) standard lengths

AX410, AX411, AX416, AX450 and AX455

Single and dual input analyzers for dissolved oxygen

Specification – Analyzers

Dissolved Oxygen – AX480, AX488 and AX468

Range

Programmable 0 ... 250% saturation, 0 ... 25 mg l^{-1} or 0 ... 25ppm

Minimum span

0 ... 2 mg l^{-1} or ppm

0 ... 20% saturation

Units of measure

% saturation, mg l^{-1} and ppm

Resolution

0.1 (% saturation), 0.01 (mg l^{-1}) or 0.01 (ppm)

Accuracy

1 (% saturation), 0.1 (mg l^{-1}) or 0.1 (ppm)

Operating temperature range

0 ... 40 °C (32 ... 104 °F)

Temperature sensor input

3-wire Pt100

Salinity correction

Automatic over the range 0 ... 40 parts per thousand

Auto sensor life indicator

Indicates conditions of remaining sensor life

pH/Redox – AX468 only

Inputs

One pH or mV input and solution earth

One temperature sensor

Enables connection to glass or enamel pH and reference sensors and Redox (ORP) sensors

Input resistance

Glass > 1 x 10¹³Ω

Reference 1 x 10¹³Ω

Range

-2 ... 16 pH or -1200 ... +1200 mV

Minimum span

Any 2 pH span or 100 mV

Resolution

0.01 pH

Accuracy

0.01 pH

Temperature compensation modes

Automatic or manual Nernstian compensation

Range -10 ... 200 °C (14 ... 392 °F)

Process solution compensation with configurable coefficient

Range -10 ... 200 °C (14 ... 392 °F)

adjustable -0.05 ... 0.02%/ °C (-0.02 ... 0.009%/ °F)

Temperature sensor

Programmable Pt100 (3-wire), Pt1000 & Balco 3k.

Calibration Ranges

Check value (zero point) 0 ... 14 pH

Slope

Between 40 and 105% (low limit user-configurable)

Electrode Calibration Modes

Calibration with auto-stability checking

Automatic one or two point calibration selectable from:

ABB

DIN

Merck

NIST

US Tech

Two x user-defined buffer tables for manual entry or

Two-point calibration or single-point process calibration

Display

Type

Dual 5-digit, 7-segment, backlit LCD

Information

16-character, single line dot-matrix

Energy-saving function

Backlit LCD configurable as ON or Auto Off after 60s

Logbook*

Electronic record of major process events and calibration data

Real-time clock*

Records time for logbook and auto-manual functions

*Available if option board is fitted

Sensor Cleaning Function

Configurable cleaning action relay contact

Continuous or

Pulse in 1s on and off times

Frequency

5 minutes ... 24 hours, programmable in 15 minute increments up to 1 hour then in 1 hour increments for 1 ... 24 hours

Duration

15s ... 10 minutes, programmable in 15s increments up to 1 minute then in 1 minute increments up to 10 minutes

Recovery period

30s ... 5 minutes, programmable in 30s increments

AX410, AX411, AX416, AX450 and AX455

Single and dual input analyzers for dissolved oxygen

Relay Outputs – On/Off

Number of relays

Three supplied as standard or five with option board fitted

Number of set points

Three supplied as standard or five with option board fitted

Set point adjustment

Configurable as normal or failsafe high/low or diagnostic alert

Hysteresis of reading

Programmable 0 ... 5% in 0.1% increments

Delay

Programmable 0 ... 60s in 1s intervals

Relay contacts

Single-pole changeover

Rating 5A, 115/230V AC, 5A DC

Insulation

2kV RMS contacts to earth/ground

Analog Outputs

Number of current outputs (fully isolated)

Two supplied as standard or four with option board fitted

Output ranges

0 ... 10 mA, 0 ... 20 mA or 4 ... 20 mA

Analog output programmable to any value between 0 and 22 mA to indicate system failure

Accuracy

±0.25% FSD, ±0.5% of reading (whichever is the greater)

Resolution

0.1% at 10 mA, 0.05% at 20 mA

Maximum load resistance

750Ω at 20 mA

Configuration

Can be assigned to either measured variable or either sample temperature

Digital Communications

Communications

Profibus DP (with option board fitted)

Control Function – AX480 Only

Controller Type

P, PI, PID (Configurable)

Control Outputs

Output

Can be assigned a maximum of two relays, two analog outputs or one of each

Analog

Current output control (0 ... 100%)

Time proportioning cycle time

1.0 ... 300.0s, programmable in increments of 0.1s

Pulse frequency

1 ... 120 pulses per minute, programmable in increments of 1 pulse per minute

Controller action

Direct or reverse

Proportional band

0.1 ... 999.9%, programmable in increments of 0.1%

Integral action time (Reset)

1 ... 7200s, programmable in increments of 1s (0 = Off)

Derivative

0.1 ... 999.9s programmable in increments of 0.1s, only available for single set point control

Auto/Manual

User-programmable

Access to Functions

Direct keypad access

Measurement, maintenance, configuration, diagnostics or service functions

Performed without external equipment or internal jumpers

AX410, AX411, AX416, AX450 and AX455

Single and dual input analyzers for dissolved oxygen

Mechanical Data

Wall-/Pipe-mount versions

IP65 (not evaluated under UL certification)
Dimensions (height, width, depth) 192 x 230 x 94 mm
(7.56 x 9.06 x 3.7 in)
Weight 1 kg (2.2 lb)

Panel-mount versions

IP65 (front only)
Dimensions (height, width, depth) 96 x 96 x 162 mm
(3.78 x 3.78 x 6.38 in)
Weight 0.6kg (1.32 lb)

Cable Entry Types

Standard – 5 or 7 x M20 cable glands
N. American – 7 x knockouts suitable for 1/2 in. Hubble gland

Power Supply

Voltage requirements

100 to 240 V AC 50/60 Hz
(90 V Min. to 264 V Max. AC)
12 to 30 V DC

Power consumption

10 W

Insulation

Mains to earth (line to ground) 2kV RMS

Environmental Data

Operating temperature limits

-20 to 55 °C (-4 ... 131 °F)

Storage temperature limits

-25 to 75 °C (-13 ... 167 °F)

Operating humidity limits

Up to 95%RH non condensing

EMC

Emissions and immunity

Meets requirements of:
EN61326 (for an industrial environment)
EN50081-2
EN50082-2

Approvals, Certification and Safety

Safety approval

UL

CE Mark

Covers EMC & LV Directives (including latest version EN 61010)

General safety

EN61010-1
Overvoltage Class II on inputs and outputs
Pollution category 2

Languages

Languages configurable

English
French
German
Italian
Spanish

AX410, AX411, AX416, AX450 and AX455
 Single and dual input analyzers for dissolved oxygen

Overall Dimensions

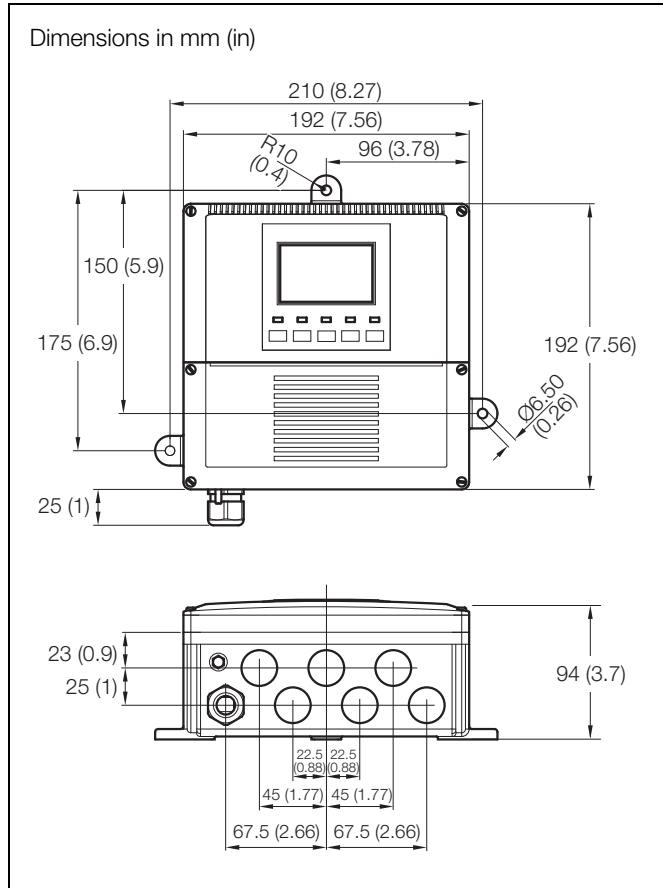

Wall-/Pipe-mount Version

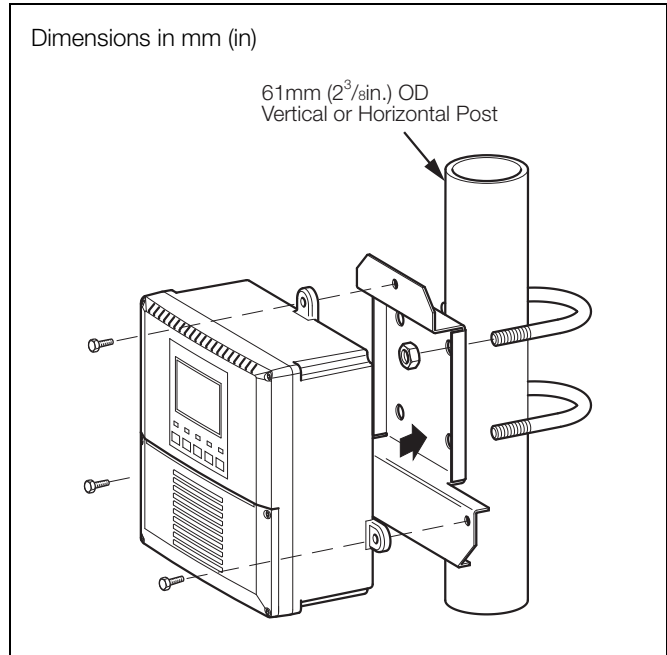

Pipe-mount Details

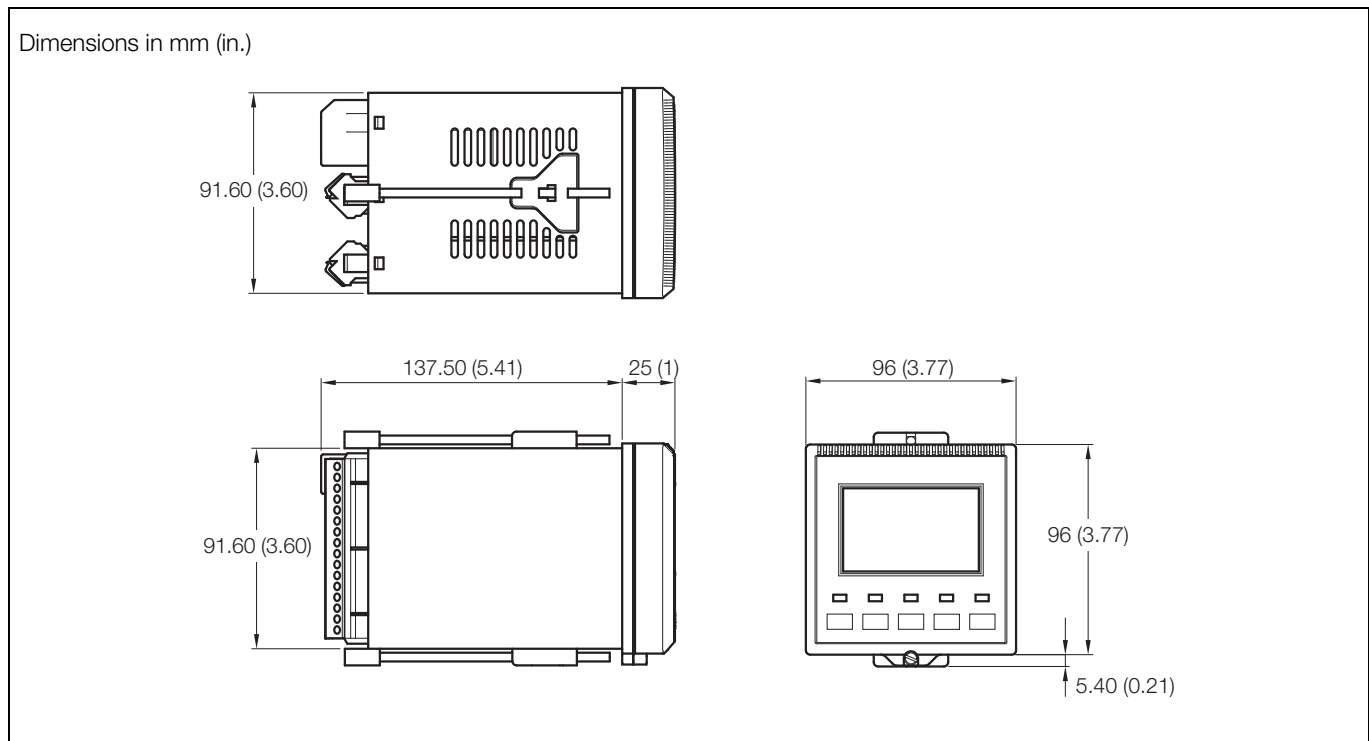

Panel-mount Version

Electrical Connections

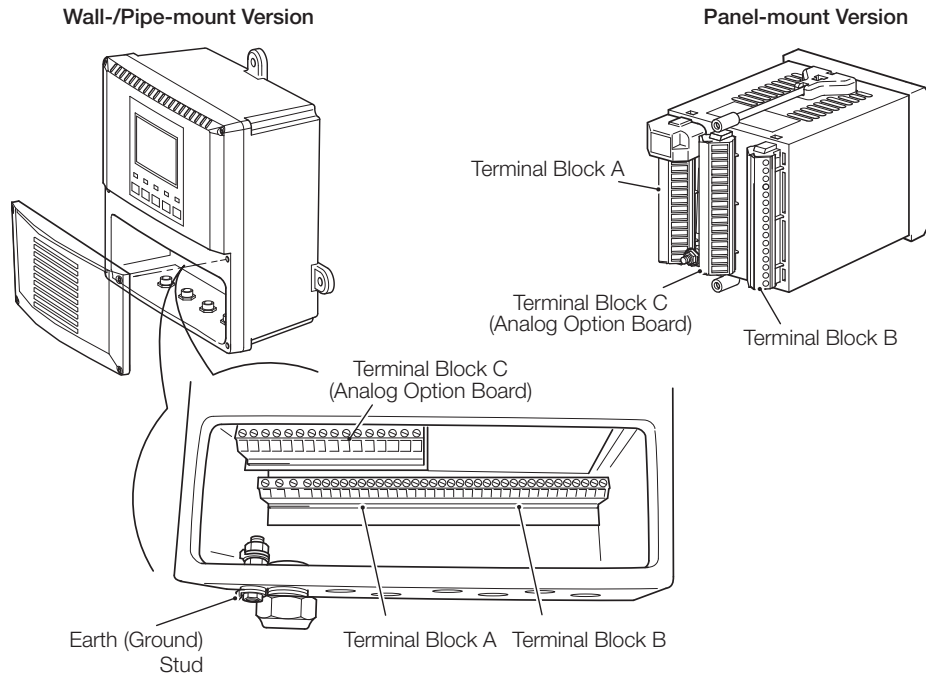

Terminal block A

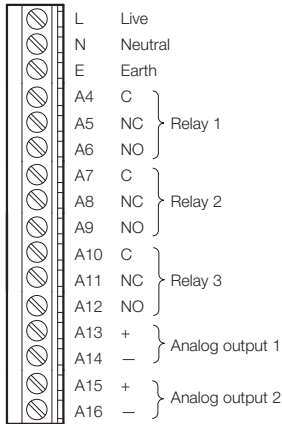

Terminal Block C (Option Board)

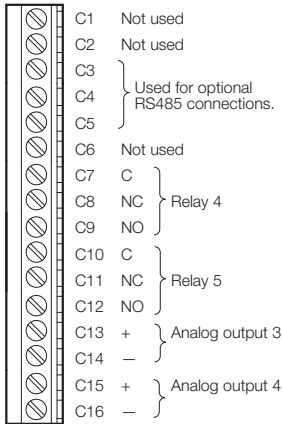

Terminal Block B (see table below)

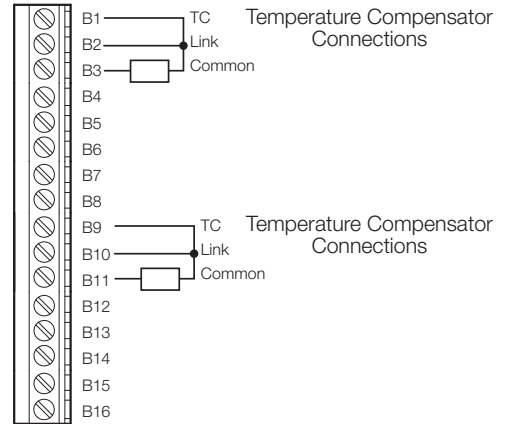

Terminal Block B		Sensor Connections
Sensor B	Sensor A	
B1	B9	Temperature compensator common (Yellow)
B2	B10	Temperature compensator third lead (Green)
B3	B11	Temperature compensator (Black)
B4	B12	Sensor +ve (Red)
B5	B13	Sensor ðve (Blue)
B6	B14	Screen
B7	B15	Not used
B8	B16	Not used

AX410, AX411, AX416, AX450 and AX455
 Single and dual input analyzers for dissolved oxygen

Ordering Information – Analyzers

Single and Dual Input Analyzers for Dissolved Oxygen and pH/Redox (ORP) Models AX480, AX488 & AX468	AX4	X	X	X	X	X	0	X
First Process Variable (PV1)								
Conductivity 0 to 10,000µS cm ⁻¹ for 2-electrode sensors		1						
Conductivity 0 to 1,999mS cm ⁻¹ for 4 electrode sensors		3						
Conductivity USP<645> for 2-electrode sensors		5						
pH/Redox (ORP)		6						
Dissolved Oxygen		8						
Second Process Variable (PV2)*								
No second process variable – select for PID control of PV1							0	
Conductivity 0 to 10,000µS cm ⁻¹ for 2-electrode sensors							1	
Conductivity 0 to 1,999mS cm ⁻¹ for 4-electrode sensors**							3	
Conductivity USP<645> for 2-electrode sensors							5	
pH/Redox (ORP)							6	
Dissolved Oxygen							8	
Enclosure Types								
Wall-mount IP65, General								
Wall-mount – cable glands fitted							1	
Pipe-mount							2	
Wall-mount IP65, North American								
Wall-mount							6	
Pipe-mount							7	
Panel-mount, Universal								
Panel-mount**							5	
Advanced Functions & Communications								
Basic (2 current outputs + 3 relays)							0	
Advanced (4 current outputs + 5 relays + logbook)							1	
Profibus DP, basic (2 current outputs + 3 relays)**							2	
Profibus DP, advanced (4 current outputs + 5 relays + logbook)**							3	
Power Supply								
100 to 240 V AC 50 to 60 Hz							0	
12 to 30 V DC							1	
Reserved								0
Manual								
English								1
French								2
Italian								3
German								4
Spanish								5

* When ordering units with a second process variable (PV2) the code digit for PV2 in the order code number must be equal to, or greater than, the code digit for PV1, e.g. AX416 permissible, AX461 not permissible.

** Profibus DP not available in panel-mount housing when 0 to 1,999mS/cm is selected as Second Process Variable (PV2).

AX410, AX411, AX416, AX450 and AX455
 Single and dual input analyzers for dissolved oxygen

Ordering Information – Sensor Systems

9408 Sensor Systems		9408	XX	X
Floating Ball Systems	Floating ball system – complete		70	
	Floating ball kit (metric) support arm supplied by user		75	
	Floating ball kit (imperial) support arm supplied by user		76	
Immersion Systems	Immersion system length 1 m (3.3 ft)		71	
	Immersion system length 2 m (6.6 ft)		72	
	Immersion system length 3 m (10 ft)		73	
Submersible Systems	Supplied with 8 m (26 ft) of fixed cable		60	
	Without cleaning			0
	Jet wash			2

9408 Sensor Systems		9408	X	X	X	X
Flow-through Cartridge			8			
Process Connection	1 in BSP			0		
	1/2 in BSP			1		
	1 in NPT			2		
	1/2 in NPT			3		
Cable Length	1 m (3.3 ft)				0	
	3 m (10 ft)				1	
	5 m (15 ft)				2	
	10 m (32 ft)				3	
	20 m (64 ft)				4	
Jet Wash	Without cleaning					0
	Jet wash					2

Contact us

ABB Limited

Process Automation

Oldends Lane
Stonehouse
Gloucestershire GL10 3TA
UK

Tel: +44 1453 826 661

Fax: +44 1453 829 671

ABB Inc.

Process Automation

125 E. County Line Road
Warminster
PA 18974
USA

Tel: +1 215 674 6000

Fax: +1 215 674 7183

www.abb.com

Note

We reserve the right to make technical changes or modify the contents of this document without prior notice. With regard to purchase orders, the agreed particulars shall prevail. ABB does not accept any responsibility whatsoever for potential errors or possible lack of information in this document.

We reserve all rights in this document and in the subject matter and illustrations contained therein. Any reproduction, disclosure to third parties or utilization of its contents in whole or in parts – is forbidden without prior written consent of ABB.

Copyright© 2011 ABB

All rights reserved

3KXA496401R1001