

control valve
type BR 13



strong
arguments
of modern technology

Three way control valve

Application

The valves are used as control elements in automatic control and remote control systems.

They are designed to control the intensity of flow of liquids and gases. They may be utilized for splitting the stream into two outlet ports (diverting service) or for mixing two fluids streams to outlet port (mixing service).

They are recommended for heating, ventilating, air conditioning and other branches of industry. They could be combined with:

Pneumatic actuators type P/R (standard) or P1/R1; P3/R3 (optional); motor operated electric actuators; hand wheel.

Valves without driving are also available.

Characteristics

- A wide range of flow ratios
- High shut-off tightness for both standard and soft seats
- Diversity of material and design selection
- Wide range of electric actuators concerning variety of types, output forces and accessories
- Pneumatic actuators conformable 94/9/EG (ATEX 100a)
- Design options for
 - oxygen service
 - liquid and gaseous fuel service
 - cryogenic service

type BR 13

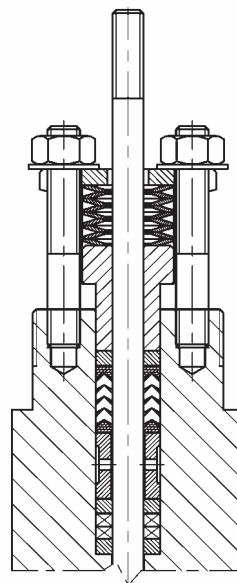
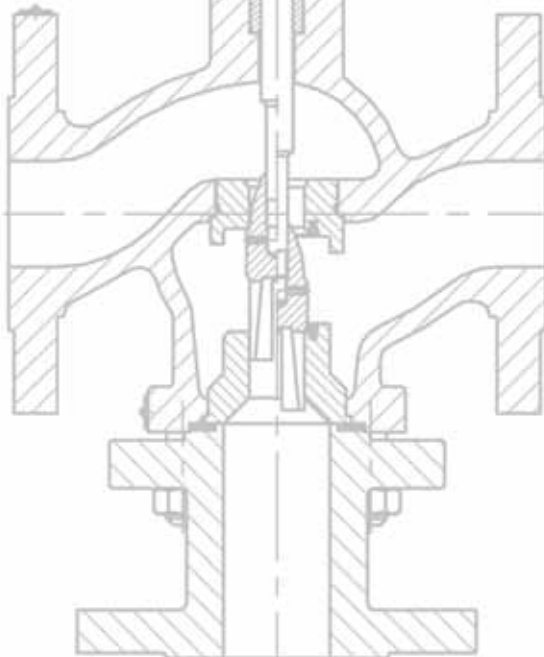

Stuffing box packing according to TA-Luft (PTFE -V-Ring)

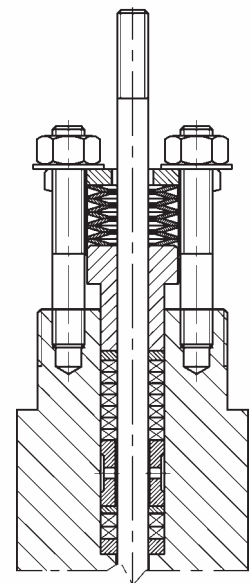

Stuffing box packing according to TA-Luft (Graphite)

Construction and technical specification

Body (1)

Flanged, cast with integrated bonnet (cast iron) or with welded bonnet (carbon steel)

Nominal diameter

DN 15; 20; 25; 32; 40; 50; 65; 80; 100; 150 (bigger sizes available on request)

Tab. 1: Nominal pressure and end connections depend on material

Material	Pressure	Connection			
		Raised face	Groove	Female face	RJ Groove
		Marking			
Cast iron	PN 10; 16; 25	B	-	-	-
Ductil iron	PN 10; 16; 25; 40	B	D	F	-
	PN 20 [150 lbs]	B1	-	-	J
	PN 50 [300 lbs]		D1	F1	
Carbon steel	PN 10; 16; 25; 40	B	D	F	-
	PN 20 [150 lbs]	B1	-	-	J
	PN 50 [300 lbs]		D1	F1	

- Acc. to PN-EN 1092-2; 1997;
- Acc. to PN-ISO 7005-1; 1996

Bonnet (1a)

Standard or extension - integrated with body; cast or welded, see tab. 2

3-Way Flange (2)

Drawn of steel, for dimensions see fig. 5 and tab. 6

Plug (3)

Contoured-fluted

- Linear flow characteristic
- Rangeability 50:1

Seat (4)

- Screwed (4.1) , fitted (4.2)
- Metal seal
- Soft (PTFE packing)

Stem (5)

Burnished or heat-treated and polished on the working surface

Sealing (7, 8)

Body gasket spiral „graphite + 1.4571“; stem packing set: PTFE V; PTFE + graphite, expansion graphite; graphite woven packing cord; TA-Luft packing

Seat leakage

- **Standard:** PN-IEC 60534-4 IV Class; metal seal
- **Bubble tight:** PN-IEC 60534-4 IV Class; soft seal

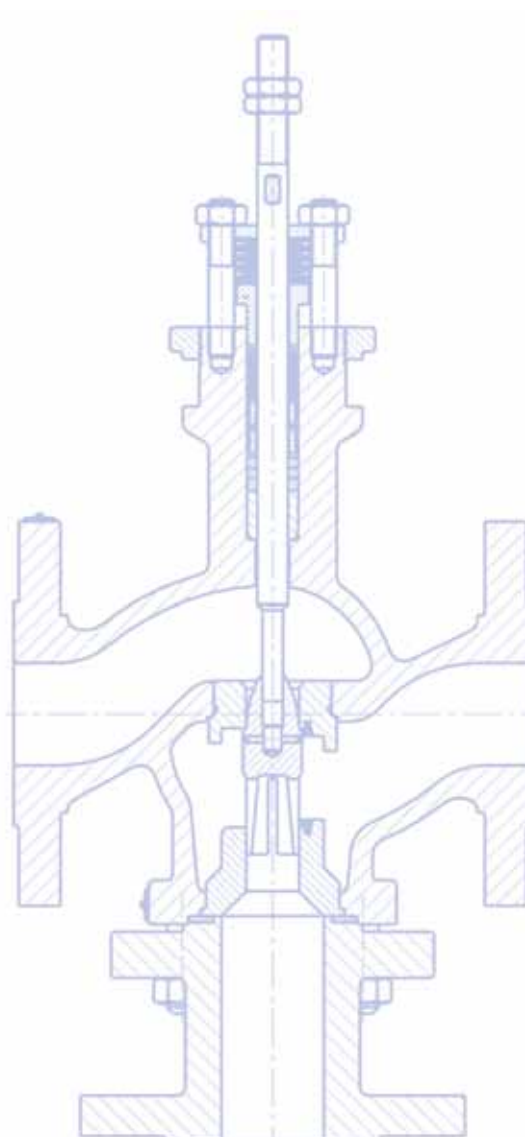

Tab. 2: Packing types and applications

Packing type	PN	Temperature [°C]	
		Body type	
		Standard	Extension bonnet
PTFE-V-Ring	10 ... 50	-46° C ... +200° C	-198° C ... -46° C
PTFE + Graphite			+200° C ... +300° C
PTFE-V-Ring / TA-Luft		+200° C ... +300° C	-
Graphite			+300° C ... +450° C
Graphite / TA-Luft			

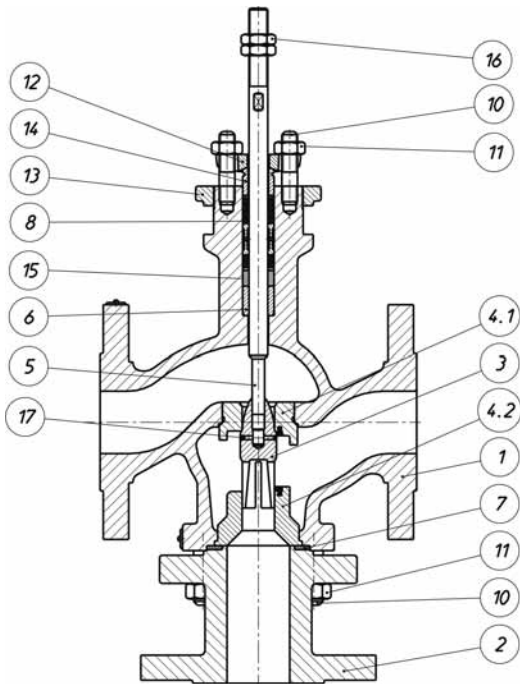

Fig. 1
Control valve

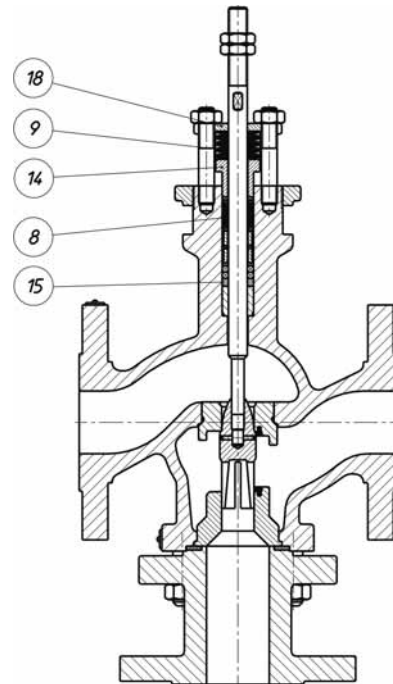
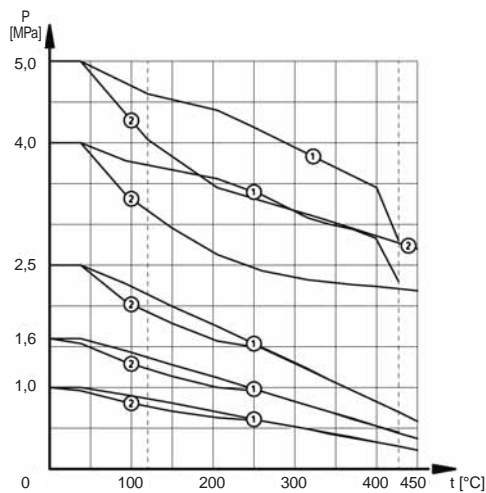

Fig. 2
Control valve equipped with TA-Luft packing

Diagram 1 - Pressure due to temperature for various carbon steels



Material	A216 WCB GP 240 GH (1.0619)	A351 CF8M / GX5CrNiMo 19-11-2
Curve No.	1	2
Temperature range	-20° C ... +427° C	-198° C ... +450° C

Diagram 2 - Pressure due to temperature for various cast irons

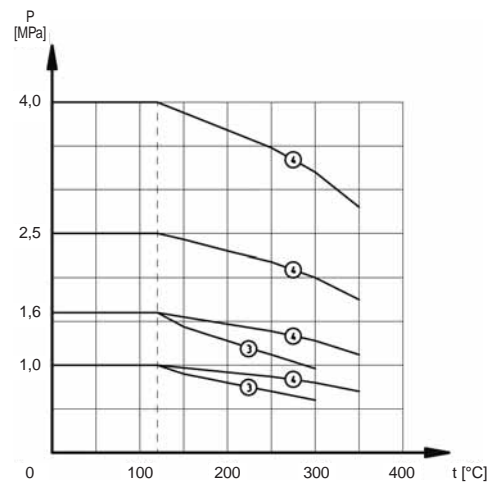

Material	EN-GJL (EN-JL 1040)	EN-GJS 400-18 (EN-JS 1025)
Curve No.	3	4
Temperature range	-10° C ... +300° C	-10° C ... +350° C

Tab. 3: Flow coefficient Kvs and design coefficients

Kvs	0,63	1,0	1,6	2,5	4,0	6,3	10	16	25	40	63	94	125	160	250	320
Stroke [mm]	20										38			50		
Seat site [mm]	12,7			19,05			20,64	25,25	31,72	41,25	50,8	66,7	88,9		107,92	126,95
DN	15															
	20															
	25															
	32															
	40															
	50															
	65															
	80															
	100															
150																
F _D [kN]	0,2	0,3		0,33		0,4		0,5	0,7	0,8	1,1	1,4		1,7	2,0	
A	1,3	2,9		3,4		5,0		7,9	14	20	35	62		92	126	
Design coefficients F _L = 0,9 ; X _T = 0,7 ; F _d = 0,41 ; xF _Z = 0,65																

Larger nominal widths (up to DN 300) on request

Tab. 4: List of parts and materials

NO.	Part name	Material		
1	Body	EN-GJS 400-18 (EN-JS 1020)	GP 240 GH (1.0619) WCB	GX5CrNiMo 19-11-2 (1.4408) CF8M
1a	Bonnet		S 355 J2G3 (1.0570)	X6CrNiMoTi 17-12-2 (1.4571)
2	Three way flange	S 355 J2G3 (1.0570)		X6CrNiMoTi 17-12-2 (1.4571)
3	Plug	X6CrNiMoTi 17-12-2 (1.4571) X6CrNiMoTi 17-12-2 (1.4571) + Stellite + CrN X17CrNi 16-2; (1.4057) + Heat-treating		
4.1	Screwed seat	X6CrNiMoTi 17-12-2 (1.4571)		
4.2	Fitted seat	X6CrNiMoTi 17-12-2 (1.4571) + Stellite X6CrNiMoTi 17-12-2 (1.4571) + PTFE X17CrNi 16-2; (1.4057) + Heat-treating		
5	Stem	X6CrNiMoTi 17-12-2 (1.4571) X17CrNi 16-2; (1.4057)		
6	Guiding sleeve	X6CrNiMoTi 17-12-2 (1.4571) + CrN X17CrNi 16-2; (1.4057) + CrN		
7	Body gasket	X6CrNiMoTi 17-12-2 (1.4571) + Graphite (spiral)		
8	Packing set	PTFE + Graphite; PTFE - „V“; Graphite		
9	Spring	12R10 (SANDVIK)		
10	Screw	8,8		A4 - 70
11	Nut	8		A4 - 70
12	Press lever	C45		
13	Nut	X6CrNiMoTi 17-12-2 (1.4571)		
14	Press sleeve	X6CrNiMoTi 17-12-2 (1.4571)		
15	Sleeve	X6CrNiMoTi 17-12-2 (1.4571)		
16	Nut	C45	X6CrNiMoTi 17-12-2 (1.4571)	
17	Peg	X6CrNiMoTi 17-12-2 (1.4571)		
18	Packing gland	X6CrNiMoTi 17-12-2 (1.4571)		

Material	Norm No.
EN-GJL 250; (EN-JL 1040)	EN 1561
EN-GJS 400-18; (EN-JS 1020)	EN 1563
GP240 GH; (1.0619)	EN 10213-2
WCB	ASTM A216
GX5CrNiMo 19-11-2; (1.4408)	EN 10213-4
CF8M	ASTM A351
S 355 J2G3; (1.0570)	EN 10025
X6CrNiMoTi 17-12-2; (1.4571)	EN 10088
X17CrNi 16-2; (1.4057)	EN 10088
C45	EN 10083-1

Note: Hardening technology of internal parts includes:

- a) Stellite - the surface is covered with stellite: ~ 40 HRC
- b) CrN coating - chrome nitride compounds are introduced into material to approx 0,1 mm down from the surface; ~ 950 HV
- c) Heat-treating: plug (~ 45HRC), seat (~ 35 HRC), stem (~ 35 HRC), guiding sleeve (~ 45 HRC)

Tab. 5: Actuator force Fs [kN]

Actuator size	P			R					
	Supply pressure [kPa]			Supply pressure [kPa]					
	140	250	400	20 - 100	40 - 120 40 - 200	60 - 140	80 - 240	120 - 280	180 - 380
250	1,0	3,8	7,5	0,5	1,0	1,0	2,0	3,0	-
400	1,6	6,0	12,0	0,8	1,6	1,6	3,2	4,8	-
630	2,5	9,5	18,9	1,3	2,5	2,5	5,0	7,6	11,3
1000	4,0	15,0	30,0	2,0	4,0	4,0	8,0	12,0	18,0

Note: a) 1. Spring range for direct acting P type actuators (P) 0,2 ... 1,0 bar
 b) The above formula is applied to calculate ΔP for motor operated electric actuators and other actuators.
 Fs value should be assumed as an actuator capacity rating according to its catalogue card.

Tab. 6: Actuator data

Actuator type	P/R			
Actuator size	250	400	630	1000
H [mm]	20		38	38; 50; 63

Tab. 6a: Spring range of actuators

Variable	Measure unit	Spring range					
p ₁ - p ₂	[kPa]	20 ... 100	40 ... 120	60 ... 140	80 ... 240	120 ... 280	180 ... 380
p _z	[kPa]	250			400		
A _s	[cm ²]	250; 400; 630; 1000				630; 1000	

- Notations:**
- H** Stroke [mm]
 - p₁ - p₂** Spring range [bar]
 - p_z** Supply pressure [bar]
 - A_s** Diaphragm effective area [cm²]
 - F_{SP1}** Directly operating actuator „P“; depressurised seal upper seat closed (screwed seat)
 - F_{SP2}** Directly operating actuator „P“; depressurised seal lower seat closed (jammed seat)
 - F_{SR1}** Reverse operating actuator „P“; depressurised seal upper seat closed (screwed seat)
 - F_{SR2}** Reverse operating actuator „P“; depressurised seal lower seat closed (jammed seat)

Formulas for calculating disposable actuator force due to service, actuator and seat type (upper or bottom seat)

$$F_s = \frac{\Delta P \times A}{10} + F_D$$

a) Mixing service $F_{SP1} = 10^{-2} p_1 \times A_s$; $F_{SR1} = 10^{-2} (p_1 - p_2) \times A_s$
 $F_{SP2} = 10^{-2} (p_z - p_2) \times A_s$; $F_{SR2} = 10^{-2} p_2 \times A_s$

b) Diverting service $F_{SP1} = 10^{-2} (p_z - p_1) \times A_s$; $F_{SR1} = 10^{-2} p_2 \times A_s$
 $F_{SP2} = 10^{-2} p_2 \times A_s$; $F_{SR2} = 10^{-2} (p_z - p_1) \times A_s$

- ΔP** Calculated pressure drop [MPa]
- F_s** Disposable actuator force [kN]
- F_D** Plug to seat pressure force (Tab. 4) [kN]
- A** Surface coefficient of seat diameter [cm²]

Tab. 7: External dimensions and connection dimensions

Dimensions		Measure unit	DN									
			15	20	25	32	40	50	65	80	100	150
A	PN 10; 16; 25; 40	[mm]	130	150	160	180	200	230	290	310	350	480
	PN 20		-	-	184	-	222	254	-	298	352	451
	PN 50		-	-	197	-	235	267	-	317	368	473
B		[mm]	140			162		184	215,5	233,5	240	288,5
C	Standard	[mm]	97			110	117	128	140	146	171	205
	Extens. bonnet		297			310	317	328	340	346	371	405
E ¹⁾		[mm]	125									175
F		[mm]	50									80
d ₁		[mm]	M12 x 1,25									M16 x 1,5
d ₂		[mm]	57,15									84,15
d ₃		-	2 1/4" - 16UN2A									3 5/6" - 16NS2A
Weight [kg]		8,5										150

¹⁾ at closed lower seat

It is not recommended for mixing service to apply spring ranges 20 ... 100 kPa and 180 ... 380 kPa. Disposable actuator forces for upper and bottom seat show too high discrepancy.

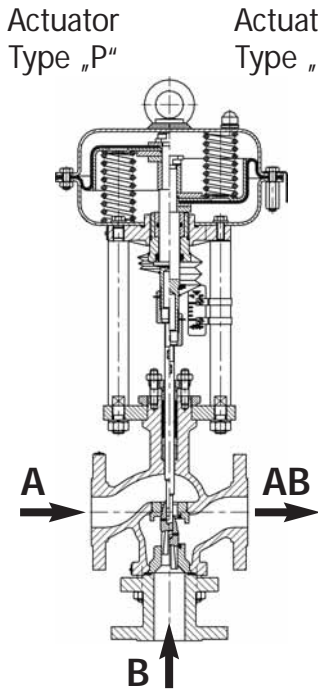

Fig. 3
P/R-BR 13
Mixing service

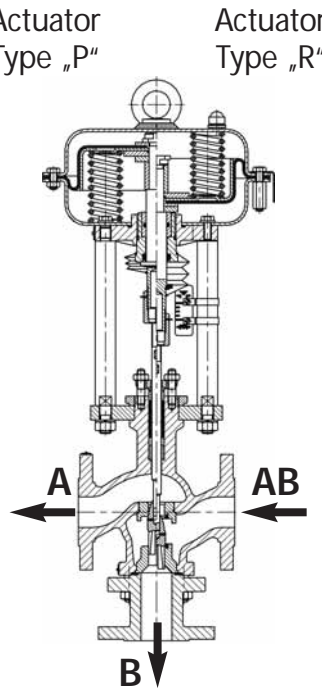

Fig. 4
P/R-BR 13
Diverting service

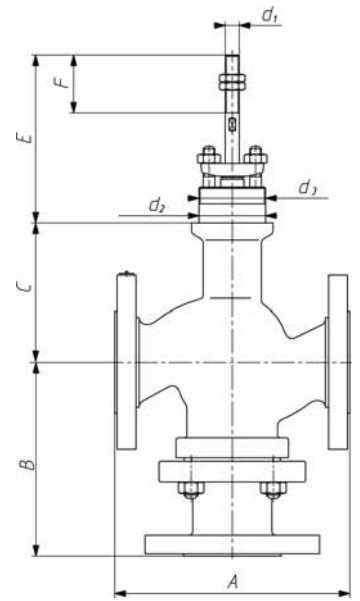

Fig. 5
External dimensions and connection dimensions

Tab.8: Pneumatic actuators for different valve sizes

Actuator type	DN									
	15	20	25	32	40	50	65	80	100	150
P/R - 250										
P/R - 400										
P/R - 630										
P/R - 1000										

Tab.9: External dimensions and weight of pneumatic actuators type P/R und PN/RN (Fig. 6)

Actuator size	D ₁	D ₂	H ₁	H ₂	Weight [kg]	
	[mm]				P/R	PN/RN
250	240	225	377	474	10	14,5
400	305		387	484	16	20,5
630	375	305	477	574	30	37
1000	477	450	638	815	74	100

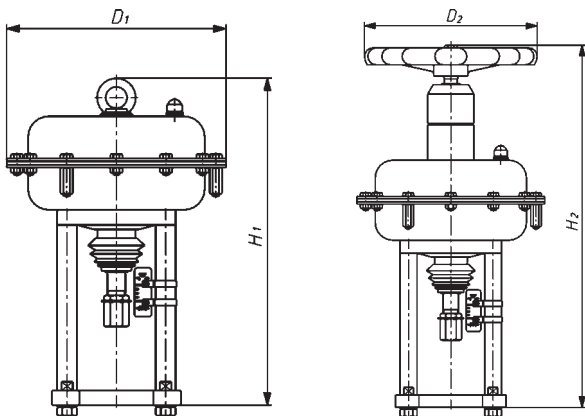

Fig. 6:
actuators
type P/R, PN/RN

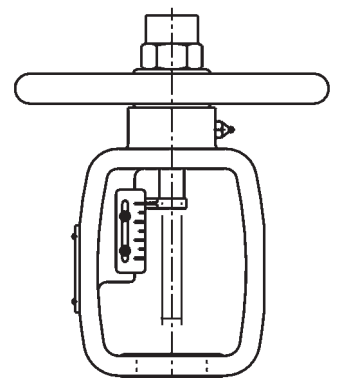

Fig. 7:
Hand wheel



**Special-purpose solutions
a problem?**

Not with PRE-VENT®-valves!

Ask our specialists!

PRE-VENT GmbH

Vertrieb - Produktion - Service
Gewerbepark Lindach A9
84489 Burghausen, Germany

Telefon: +49 8677 98788-0
Telefax: +49 8677 98788-80

E-Mail: office.pre-vent@fiwagroup.com
Internet: www.pre-vent.com

SEITA

Soluciones en Instrumentación,
Automatización y Control Industrial

www.seita.com.co



strong
arguments
of modern technology