

AV410, AV411, AV420, AV412 and AV422 Single and dual input dissolved organics monitor

A robust, easy-to-use range of continuous on-line monitors



Dual input enables two measurements from one instrument, each input can be either high range or low range

- cost effective

Surrogate color measurement

- significant savings on operational costs through lower maintenance requirements

Savings on alum or ferric are achieved on potable water treatment plants

- coagulation control cost saving

Less alum, less sludge

- reduced sludge disposal costs

THM (trihalomethanes) precursor alert

- provides advanced warning of increased risk of THM development

Automatic compensation for turbidity

- reduces initial capital expenditure, minimizing operational costs

Reagentless operation

- significant savings in operational expenditure

On-line diagnostics

- cleaner failure, loss of signal, out of sample

SEITA

Servicios Especializados de Ingeniería
en Tecnología y Automatización

www.seita.com.co

Power and productivity
for a better world™



AV400 Series Dissolved Organics Monitors

Many dissolved organic carbon compounds (DOC) commonly found in potable water absorb ultraviolet radiation. These include Humic and Fulvic Acids that gives water a characteristic yellow color. Dissolved organics can also result in the formation of Trihalomethanes (THMs) as a by-product of chlorination.

The AV400 Series of monitors are designed for optimizing the performance of potable water treatment plants, providing significant cost savings and ensuring the quality of the final treated water.

AV410/AV411 Single and Dual Low Range Dissolved Organics Monitors (0 to 20mg⁻¹C) are designed for use on potable water treatment plants. In particular, they can be used to monitor the quality of the outlet from sand and carbon filters to provide a THM precursor measurement. Long term field trials have shown that maintenance demands on these applications are minimal.

AV420/AV422 Single and Dual High Range Dissolved Organics Monitors (0 to 100mg⁻¹C) are specifically designed to provide surrogate color monitoring on the incoming raw water in potable water treatment plants for predictive control of the coagulant. They can also be used to detect the rise in dissolved organic carbon from algal bloom toxins in rivers and reservoirs to provide intake protection on potable water applications .

AV412 Dual High and Low Range Dissolved Organics Monitor conveniently combines the high and low range measurements so that both the pre-coagulation and post sand filter samples can be monitored.

The measured value is updated every 2 seconds when the lamp is flashed and is calculated from over 200 readings that are taken during the brief flash duration. This technique has demonstrated, during extensive field trials, superior sensitivity and performance when compared with traditional color measurement methods.

Turbidity Compensation

In addition to the absorption measurement at 254nm, a second measurement at 400nm enables the monitor to compensate automatically for fluctuations in turbidity. The significant benefits of a straight-through system, without the need for expensive and maintenance-intensive sample filter systems, ensures long-term reliability, essential for on-line control.

Reagentless Operation

The monitor uses no chemical reagents during operation, reducing cost of ownership to an absolute minimum. When compared to a color monitor (the traditional method of coagulation control), the cost of ownership, together with the initial capital purchase cost, can be recovered in 2 years.

Maintenance

Minimal maintenance is required due to the simplicity of the monitor. Apart from periodic validation of the calibration of the monitor and annual replacement of the wiper blades, there is no need for manual intervention.

Calibration

Calibration is a simple procedure using high-quality demineralized water for zero and a suitable phthalate calibration standard to adjust the span.

The monitor design ensures that the system is extremely stable and calibration needs to be performed only once or twice a year.

Installation of the Sensor

A wall-mount bracket is supplied as standard to enable the flow-through sensor to be mounted on the back-plate.

Alarms

Three alarms are supplied as standard. These can be configured as high or low programmable alarms or as a status alarm.

Light Source

The light source is monitored continuously for correct operation and is operated at a fraction of the normal frequency of the operating voltage intended by the manufacturer. Only 13% of the rated lamp life is used in 10 years. This results in a very stable light source, keeping operating costs to a minimum.

Auto-Cleaning

Optical cleaning is a key feature, ensuring optimum performance with the minimum of manual intervention. The cleaning interval is programmable to accommodate varying sample conditions.



Auto-cleaning Mechanism

AV400 Series Transmitter

The transmitter incorporates the latest technology to provide a highly reliable, yet flexible, feature-packed device designed to satisfy a diverse range of process monitoring and control applications. On dual-input monitors both measured parameters are displayed simultaneously.

High Functionality as Standard

The display can show inferred values, enabling the monitor to be configured to provide the information most valuable to the user. A correction factor must be provided and entered by the user to make inferred units useful. The inferred units include:

- Absorbance units/meter
- Color (H)
- Coagulant Dose (mg/l)
- TOC (mg/l)
- User Defined

All versions are supplied with two fully isolated current outputs as standard. Both outputs can be ranged independently on single input versions. Each one can be assigned to either sensor input on dual input versions.

Three programmable relay set points are available that can also be assigned as required.

Innovative features such as a power saving display and a diagnostic current output option all contribute to a low cost of ownership.



Dissolved Organic Display

Significantly Reduced Maintenance Costs

The transmitters are supplied as standard for 85 to 265V AC operation. There are no inner switches to be set.

The transmitters can also be provided for 9 to 36V DC operation that reduces maintenance costs significantly by removing the need for costly, annual safety tests to ensure compliance with safety procedures.

Energy Saving Display

The backlit display is designed to operate in all types of environment and shows the measured parameter(s) and, on a separate 16-character display line, diagnostic and computed information.

For energy conservation, the backlight can be set to switch off automatically after 60 seconds of inactivity.

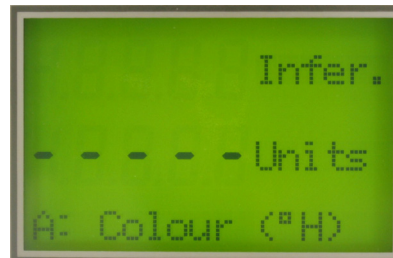

Backlight Can Be Set to Switch-off When Inactive

Easy Access Installation Terminals

Easy access to the terminations ensures rapid and cost-effective installation. The wall-/pipe-mount version is designed to ensure that cable connection is simple and convenient. Ingress protection of the electronics section is retained even when the terminal compartment is opened.



AV400 Termination Chamber Makes Access Easy

Applications

There are many applications where the AV400 Dissolved Organics Monitor can be used to improve on more traditional methods of measurement and control of water quality.

Surrogate Color Monitor for Coagulation Control

Extensive field trials have established that the AV400 High Range Dissolved Organics Monitor performs well as a surrogate color monitor on applications where the major color constituents of the raw water are humic and fulvic acids. These acids are organic compounds that readily absorb at 254nm.

Reliable and extremely cost-effective on-line control can be achieved using this compact and simple-to-install monitor.

Benefits:

- Reagentless operation
- Automatic cleaning
- Virtually maintenance-free
- Long lamp life
- High stability
- Improved water quality

Potential cost savings:

- Reduced manpower
- Improved process control
- Reduced sludge disposal costs

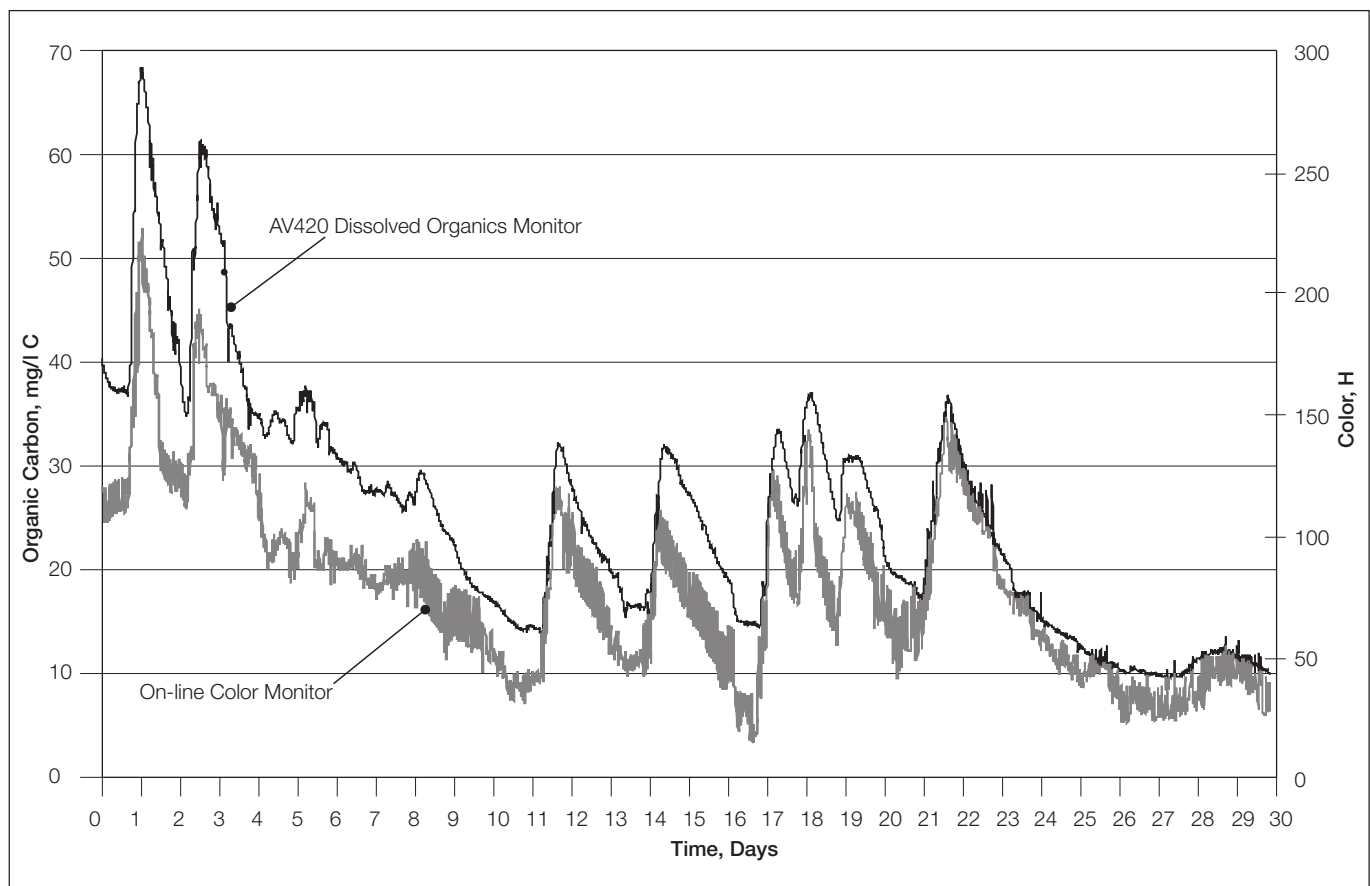

Typical Correlation Between True Color and Absorbance at 254nm in Potable Water

Algal Bloom Toxins

The formation of toxins as a result of the decomposition of algal blooms, that die out during cold periods, frequently cause taste and odor problems and a risk of THMs (Trihalomethanes) in the final treated water. It has been shown that monitoring the DOC (dissolved organic carbon compounds) in the raw water gives an early warning of these events so the appropriate action can be taken. This often involves the addition of powdered activated carbon at the coagulant dosing point.

Trihalomethanes (THMs)

The water reaching the disinfection stage of the potable treatment process may contain organic compounds from any of three sources:

Humic and fulvic acid breakthrough from the coagulation and filtration stage of the plant

Organic compounds from the decomposition of dead algal blooms

Organic compounds from industrial effluent and sewage discharges into the raw water source.

These pass through the coagulation stage but can be removed by an activated carbon stage.

These sources can give rise to a range of organic compounds that, if conditions are right, will react with the chlorine used for disinfection to form THMs. The organic compounds are referred to as THM precursors. THMs are recognized carcinogens, they are known to cause miscarriages, and are also linked to heart, lung, kidney, liver, and central nervous system damage.

Increasing concerns over THMs have resulted in the need for advance warning of the unfavourable conditions that could encourage the development of THMs in drinking water.

When used on final chlorinated water, the monitor provides advance warning of any increase in dissolved organic carbon, thereby enabling rapid corrective action to reduce the risk. Under such clean water conditions the maintenance becomes virtually zero.

Many of the low-range monitors are now used for this increasingly critical application, often in conjunction with turbidity measurement.

Specification

General

Sensor range

(Based on potassium hydrogen phthalate calibration standards)

AV410/411 Low range 0 to 20mg^l-¹C

AV420/422 High range 0 to 100mg^l-¹C

Linearity

Low range ±2% of reading or 0.15mg^l-¹C whichever is the greater

High range ±2% of reading or 0.5mg^l-¹C whichever is the greater

Reproducibility

Low range ±0.15mg^l-¹C

High range ±0.5mg^l-¹C

Inferred units

Absorbance units/metre

Color (°H)

Coagulant dose (mg^l-¹)

TOC (mg^l-¹)

User Defined

Maximum current output scale expansion

Low range 0 to 2mg^l-¹C

High range 0 to 20mg^l-¹C

Response time

Normally three minutes for 90% step change depending on damping factor

Lamp life

Rated by the manufacturer at 1.2 x 10⁹ flashes (10 years continuous operation at the rate of one flash at 2s intervals [typical] equates to 13.1% of the rated lamp life)

Internal wiper cleaning system

Programmable, operation frequency 15, 30, 45 and 60 minutes 2, 4, 6, 12 and 24 hours

Maximum distance between transmitter and sensor

750mm (29.5 in.)

Sample

Flow rate

0.5 to 5l min⁻¹ (free of air bubbles).

A higher flow rate is required at high turbidity levels

Temperature

0 to 40°C (32 to 104°F)

Pressure

The sensor should be operated at atmospheric pressure but can withstand 3bar (43.4 psi) max.

Display

Type

Dual 4 1/2-digit, 7-segment backlit LCD

Information

16-character, single line dot matrix

Resolution

Low range 0.01mg^l-¹

High range 0.1mg^l-¹

Energy saving function

Backlit LCD configurable as ON or Auto Off after 60 seconds

Logbook

Electronic record of major events and calibration data

Real-time clock

Records time for logbook and auto cleaning

Diagnostics

Out of sample

Lamp disabled

Loss of signal

Electronic failure

Languages

English

French

German

Italian

Spanish

Outputs

Current Outputs

Number of signals

2 fully isolated current outputs supplied as standard, configurable to one or both sensor outputs

Current outputs also programmable to any value between 0 and 22mA to indicate system failure

Output current

0 to 10mA, 0 to 20mA or 4 to 20mA

Maximum load resistance

750Ω at 20mA

Accuracy

±0.25% FSD ±5% of reading

Resolution

0.1% at 10mA, 0.05 at 20mA

Serial communication

PROFIBUS

...Specification

Relay outputs

Number of relays

Three supplied as standard,
configurable to one or both sensor inputs or status

Set point adjustment

Fully programmable as normal or failsafe, high/low or status

Hysteresis

Programmable 0 to 5% in 0.1% increments

Delay

Programmable 0 to 100 minutes in 1 minute intervals

Relay contacts

Single-pole changeover

Rating 5A 115/230V AC, 5A DC

Insulation

2kV RMS contacts to earth/ground

Power supply

Voltage requirements

100 to 240 V AC, 50/60 Hz
(90 V Min. to 264 V Max. AC)

Optional 12 to 30 V DC

Power consumption

20 W

Insulation

Mains to earth (line to ground) 2kV RMS

Mechanical Data

Transmitter

IP65 (not evaluated under UL certification)

Dimensions 192mm (7.56 in.) high x 230mm (9.06 in.) wide x
94mm (3.7 in.) deep

Weight 1kg (2.2 lb)

Sensor

Low Range Dimensions 327mm (12.87 in.) wide
x 410mm (16.14 in.) high x 162mm (6.38 in) deep

High Range Dimensions 405mm (15.94 in.) wide
x 373mm (14.68 in.) high x 136mm (5.35 in) deep

Weight 6kg (13.2 lb)

Cable entry types

Standard 5 or 7 x M20 cable glands

N. American 7 x knockouts suitable for 1/2 in. Hubble gland

Environmental Data

Operating temperature limits

0 to 50°C (32 to 122°F)

Storage temperature limits

-25 to 75°C (-13 to 167°F)

Operating humidity limits

Up to 95%RH non-condensing

EMC emissions and immunity

Meets requirements of:

EN61326 (for an industrial environment)

EN50081-2

EN50082-2

Approvals, Certification and Safety

Safety approval

UL

CE Mark

Covers EMC & LV Directives (including latest version EN 61010)

General safety

EN61010-1

Overvoltage Class II on inputs and outputs

Pollution Category 2

Overall Dimensions

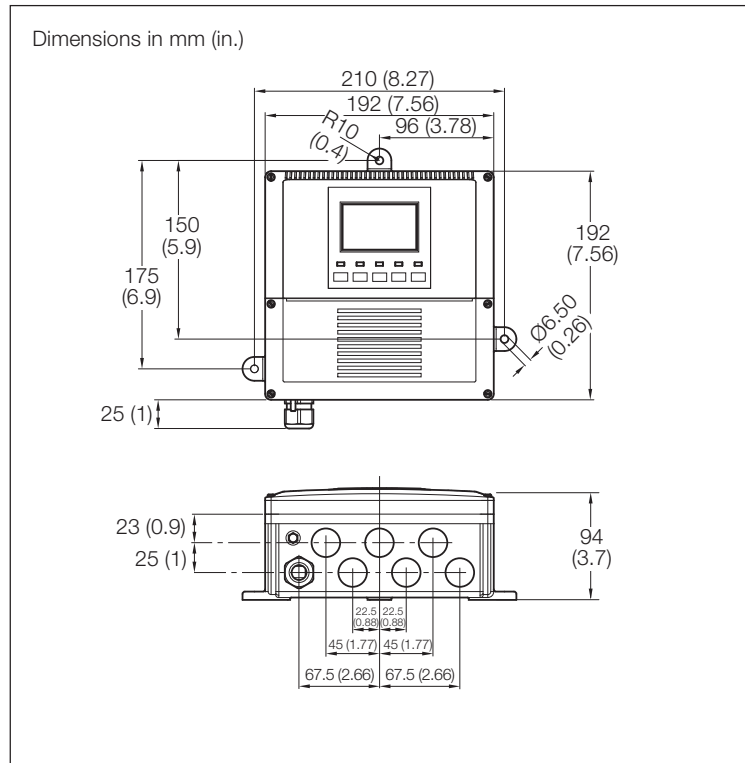

Transmitter

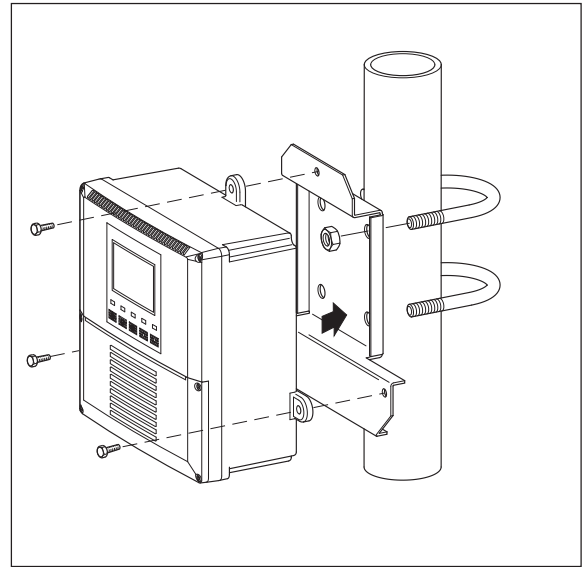

Pipe-mount Details

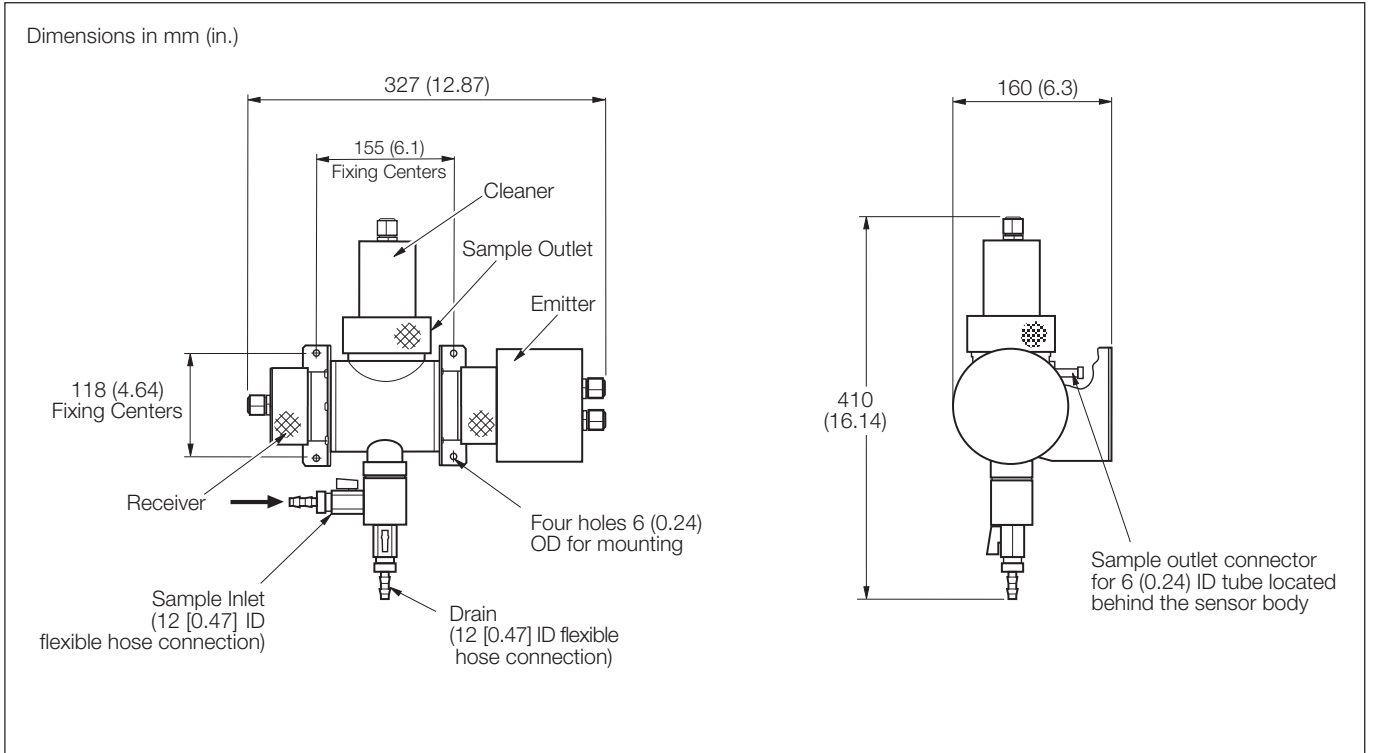

Low Range Sensor

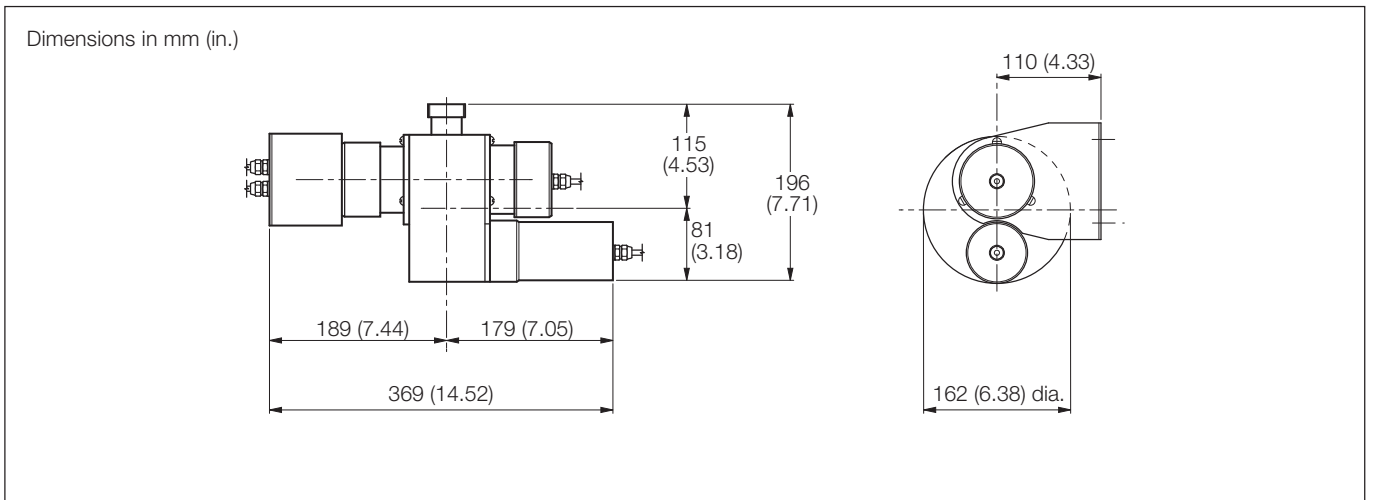

High Range Sensor

Electrical Connections

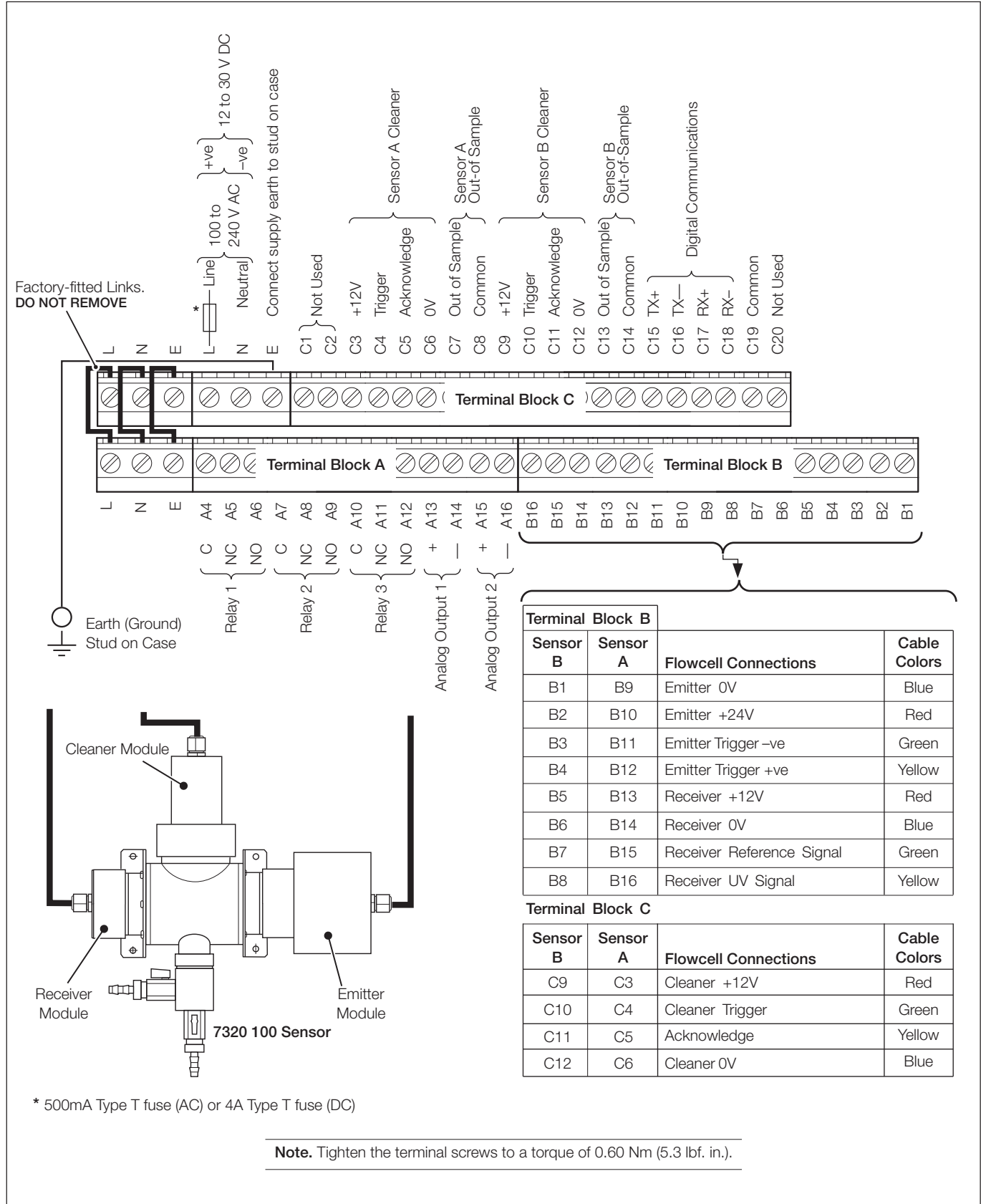

Ordering Information

Single & Dual Dissolved Organics Monitors for Potable Water Treatment AV410, AV411, AV420, AV412 & AV422	AV4	X	X	/X	X	X	0	X
Parameter 1								
Low range dissolved organics		1						
High range dissolved organics		2						
Parameter 2								
None			0					
Low range dissolved organics*			1					
High range dissolved organics			2					
Transmitter Enclosure Types								
Wall – IP65 General								
Wall-mount – cable glands fitted				/1				
Wall-mount – cable glands fitted, complete with pipe-mount bracket				/2				
Wall – IP65 N. American								
Wall-mount				/6				
Wall-mount complete with pipe-mount bracket				/7				
Serial Communications								
None						0		
PROFIBUS (pending)						2		
Power Supply								
100 to 240 V AC, 50 to 60 Hz							0	
12 to 30 V DC							1	
Reserved								0
Manual								
English								1
French								2
Italian								3
German								4
Spanish								5

* Not available when High range dissolved organics selected for Parameter 1.

Contact us

ABB Limited

Process Automation

Oldends Lane
Stonehouse
Gloucestershire GL10 3TA
UK

Tel: +44 1453 826 661

Fax: +44 1453 829 671

ABB Inc.

Process Automation

125 E. County Line Road
Warminster
PA 18974
USA

Tel: +1 215 674 6000

Fax: +1 215 674 7183

www.abb.com

Note

We reserve the right to make technical changes or modify the contents of this document without prior notice. With regard to purchase orders, the agreed particulars shall prevail. ABB does not accept any responsibility whatsoever for potential errors or possible lack of information in this document.

We reserve all rights in this document and in the subject matter and illustrations contained therein. Any reproduction, disclosure to third parties or utilization of its contents in whole or in parts – is forbidden without prior written consent of ABB.

Copyright© 2011 ABB

All rights reserved

3KXA873402R1001

DS/AV4ORG-EN Rev. D 03.2011